

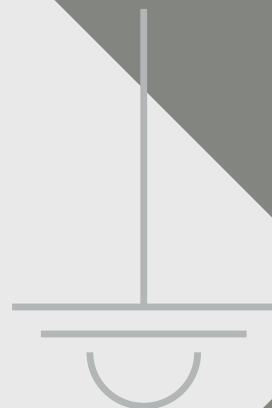

Quadrifoglio Group

# Lighting & Acoustic Collection



## Decorative Lighting Index



TABLE LAMPS

06 - 55



FLOOR LAMPS

56 - 105



PENDANT LAMPS

106 - 237



WALL/CEILING LAMPS

238 - 307

## Architectural Lighting Index



PENDANT LAMPS

308 - 330



WALL/CEILING LAMPS

308 - 330

## Office Lighting Index



TABLE LAMPS

332 - 343



FLOOR LAMPS

344 - 361



PENDANT LAMPS

362 - 373



ACOUSTIC ELEMENTS

374 - 399

## Decorative Lighting

**Light emotions.  
Soft, sinuous or geometric  
lines: decorative lamps are  
available in different covers,  
materials, textures and colours.  
Every single detail is designed  
to create an appealing  
ambience in living, hospitality  
and business interiors.**

**Emozioni di luce.**  
Linee morbide, sinuose o geometriche: le lampade decorative  
sono disponibili in diversi rivestimenti, materiali, texture e colori.  
Ogni dettaglio è studiato per creare atmosfere suggestive in  
ambienti living, hospitality e business.

## Products Index

Decorative Lighting



### TABLE LAMPS

AFRA - 8  
BALANCE - 14  
CD LED - 20  
GRACE - 32  
HALF MOON - 38  
OLA - 44  
SUN - 50



### FLOOR LAMPS

AFRA - 58  
BABEL - 64  
CD LED - 70  
GRACE - 76  
HALF MOON - 82  
OLA - 88  
WARM - 100



### PENDANT LAMPS

ADD - 108  
AFRA - 114  
BABEL - 120  
BLONDE - 126  
CD LED - 132  
DRINK - 140  
ESCAPE - 146  
GOUT - 152  
GRACE - 158  
HALF MOON - 164  
MIRAGE - 170  
OLA - 176  
OLA FLY - 182  
PIPES - 188  
PLANET - 194  
SLICE - 202  
STARLIGHT - 208  
SUN - 214  
SVEVA - 220  
TUBE - 226  
TUBE MICRO - 232



### WALL/CEILING LAMPS

ALALUNGA - 240  
CD LED - 246  
DRINK - 252  
ESCAPE - 258  
OLA SLIM - 264  
SHADOW - 270  
SLICE - 276  
STARLIGHT - 282  
TUBE - 288  
TUPLA - 296  
TURN ME! - 302

# Family Index

Decorative Lighting



ADD

ADD PENDANT - 108

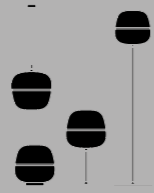

AFRA

AFRA TABLE - 8  
AFRA FLOOR - 58  
AFRA PENDANT - 114



ALALUNGA

ALALUNGA WALL - 240



BABEL

BABEL FLOOR - 64  
BABEL PENDANT - 120

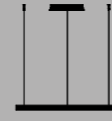

PLANET

PLANET PENDANT - 194



SHADOW

SHADOW WALL - 270



SLICE

SLICE PENDANT - 202  
SLICE WALL/CEILING - 276

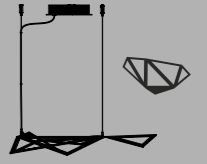

STARLIGHT

STARLIGHT PENDANT - 208  
STARLIGHT WALL - 282

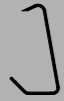

BALANCE

BALANCE TABLE - 14



BLONDE

BLONDE PENDANT - 126

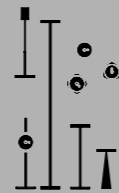

CD LED

CD LED TABLE - 20  
CD LED FLOOR - 70  
CD LED PENDANT - 132  
CD LED WALL - 246



DRINK

DRINK PENDANT - 140  
DRINK CEILING - 252



SUN

SUN TABLE - 50  
SUN PENDANT - 214

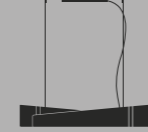

SVEVA

SVEVA PENDANT - 220



TUBE

TUBE PENDANT - 226  
TUBE WALL/CEILING - 288



TUBE MICRO

TUBE MICRO PENDANT - 232

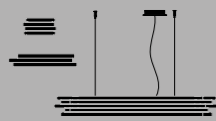

ESCAPE

ESCAPE PENDANT - 146  
ESCAPE WALL - 258



GOUT

GOUT PENDANT - 152

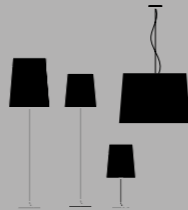

GRACE

GRACE TABLE - 32  
GRACE FLOOR - 76  
GRACE PENDANT - 158

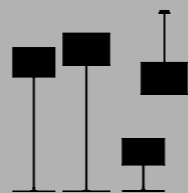

HALF MOON

HALF MOON TABLE - 38  
HALF MOON FLOOR - 82  
HALF MOON PENDANT - 164



TUPLA

TUPLA WALL - 296



TURN ME!

TURN ME! WALL - 302



WARM

WARM FLOOR - 100



MIRAGE

MIRAGE PENDANT - 170

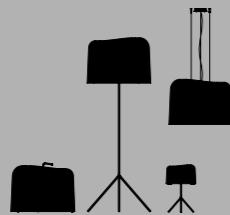

OLA

OLA TABLE - 44  
OLA FLOOR - 88  
OLA PENDANT - 176



OLA SLIM

OLA FLY PENDANT - 182  
OLA SLIM WALL/CEILING - 264



PIPES

PIPES PENDANT - 188

# Family Index

Decorative Lighting



# Table Lamps

Decorative Lighting



## Table lamps

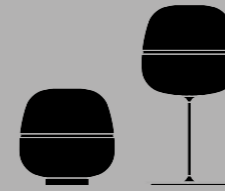

AFRA

AFRA TABLE - 8



BALANCE

BALANCE TABLE - 14

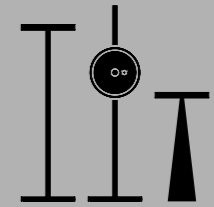

CD LED

CD LED TABLE - 20



GRACE

GRACE TABLE - 32



HALF MOON

HALF MOON TABLE - 38



OLA

OLA TABLE - 44



SUN

SUN TABLE - 50





designed by Enrico Franzolini

**Opal transparency.  
Opaline glass and painted  
aluminium converge in the full-  
bodied shape of Afra, available  
in the version with pedestal  
and support base. The light is  
diffused and dimmable, ideal for  
bedside cabinets, cupboards  
and receptions.**

Trasparenze d'opale.

Vetro opalino e alluminio verniciato si incontrano nella forma piena di Afra, disponibile nelle versioni con piedistallo e base d'appoggio. La luce è diffusa e dimmerabile, ideale per comodini, madie, consolle e reception.



TABLE LAMPS





## Table lamp

AFRA

Table lamp with white acid etched blown glass shade and powder coated metal frame.  
Lampada da tavolo con paralume in vetro soffiato acidato bianco e base in metallo verniciato.

MAX 1XE27 100W  
220-240V  
ON-OFF | Dimmer

CE IP20

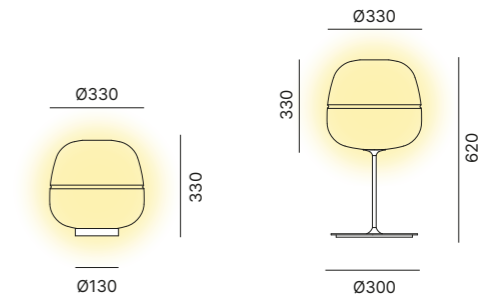

### SHADE FINISH OPTIONS FINITURE PARALUME



White acid-etched glass

### CAP (optional) CUFFIA (opzionale)



Beige

Black

### FRAME FINISH OPTIONS FINITURE STRUTTURA

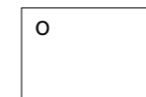

Matt White



Black Goffratino



Gold



Bronze



Corten

## Afra collection

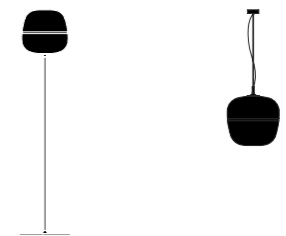

AFRA FLOOR  
58

AFRA PENDANT  
114



# BALANCE

designed by Thomas Feichtner

**Dynamic balance.  
Balance arises from an  
essential design: tubular  
curved aluminium defines a  
minimal and slender structure  
that can be positioned  
horizontally or vertically, to  
direct light on the table in the  
office or in the home office.**

Equilibrio dinamico.

Balance è frutto di un disegno essenziale: l'alluminio tubolare curvato tratteggia una struttura minimal e sottile, orientabile in orizzontale e in verticale per direzionare la luce sul tavolo in ufficio o nell'home office.



TABLE LAMPS

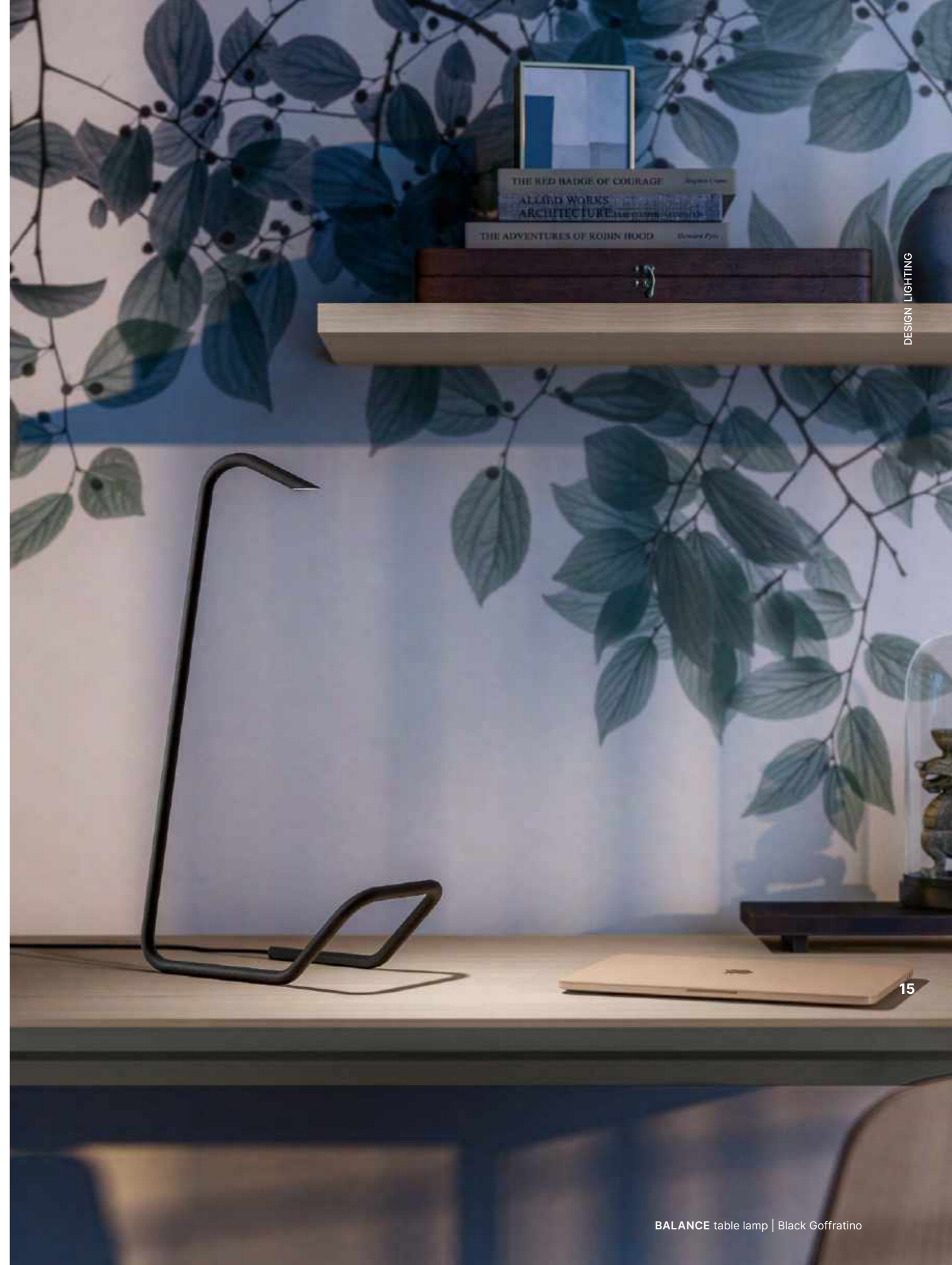

BALANCE table lamp | Matt White  
X9 executive desk | Elm top and Matt White legs  
DIVA SOFT executive chair | C05/280 fabric and Chrome frame

Lighting & Acoustic Collection







## Table lamp

## BALANCE

Table lamp in white or black painted aluminium.  
Lampada da tavolo in alluminio verniciato bianco o nero.

3W LED  
110-240V  
2700 K  
CRI80  
ON-OFF

CE IP20  120lm

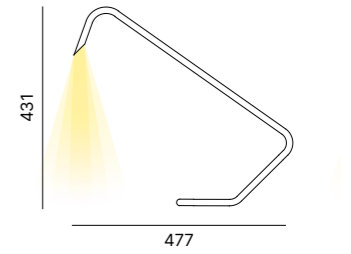
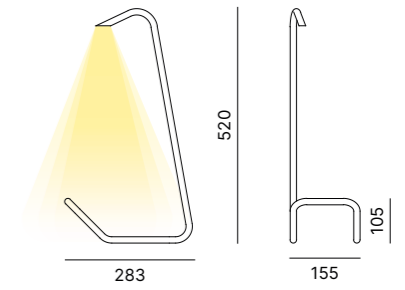

### LAMP FINISH OPTIONS FINITURE LAMPADA



Matt White    Black Goffratino



designed by Moreno De Giorgio

**Geometries of style.  
An minimalistic lamp, with  
a sophisticated soul and an  
assemblable structure.  
CD Led can be customised in  
terms of shape and colour, to  
adapt it to tables in different  
settings, including residential  
and hospitality use.**

Geometrie di stile.

Una lampada minimale, con un'anima sofisticata e una struttura multiforme: CD Led si può personalizzare nelle forme e nei colori per adattarla ai tavoli di diversi contesti, residenziali e ricettivi.



TABLE LAMPS







**The CD Led base is available in a conical or circular version and the structure can be completed with a geometric element, available in a circular, square or triangular shape and customisable in numerous colours.**

Il basamento di CD Led è disponibile in versione conica o circolare e la struttura si può completare con un elemento geometrico a scelta tra cerchio, quadrato e triangolo, customizzabile in numerosi colori.







**The powerful led light is adjustable with a mechanical dimmer, ideal for lighting reception areas, coffee tables, living room tables and bedside cabinets with personality.**

La luce a led è potente e regolabile tramite un meccanismo dimmer, ideale per illuminare con personalità reception, tavolini, tavoli della zona giorno e comodini dell'area notte.

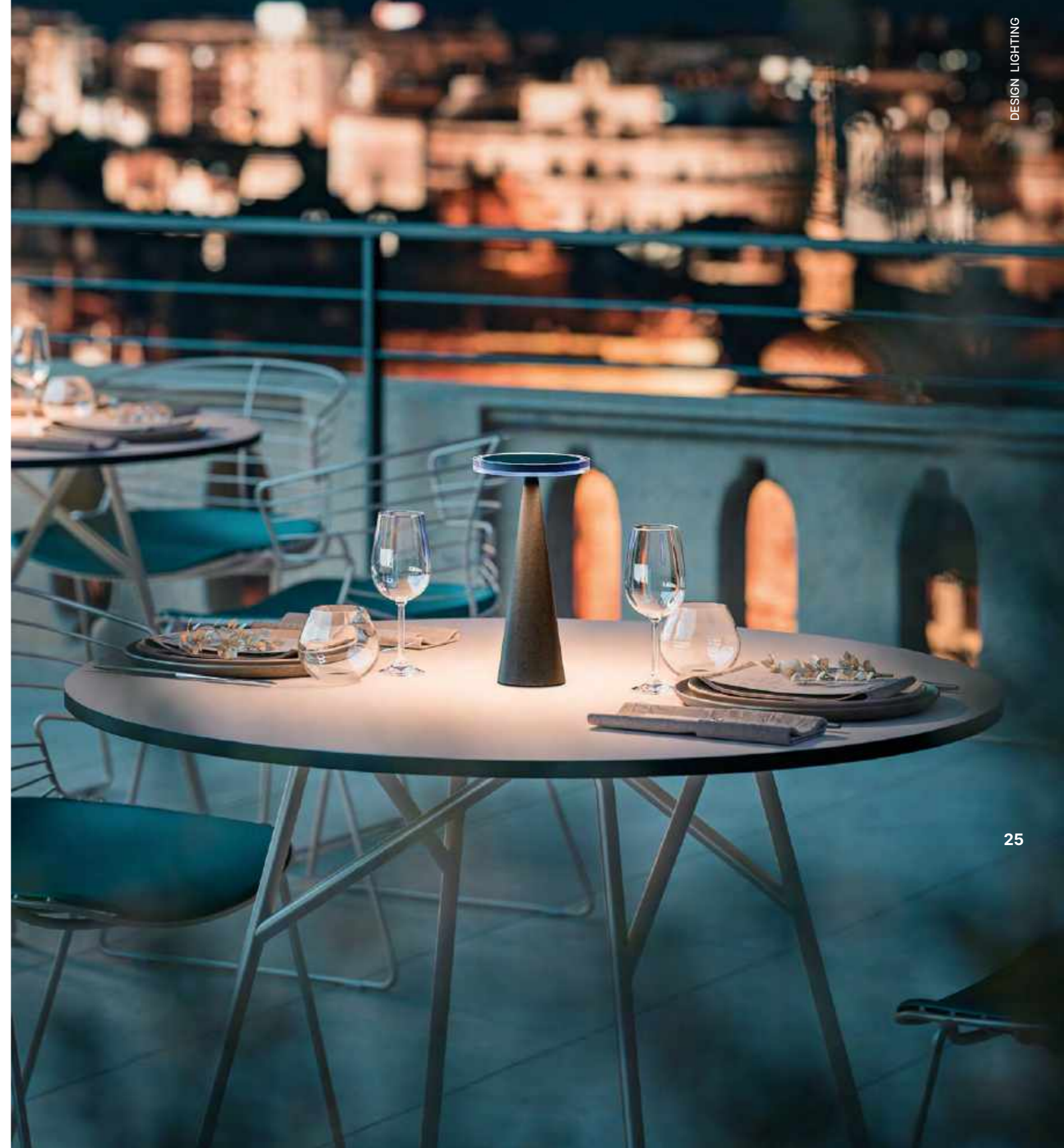







Table lamp

CD LED

Polycarbonate lamp diffuser with transparent or colored PMMA ring, powder coated metal frame.  
 Diffusore in policarbonato con anello in PMMA trasparente o colorato, struttura in metallo verniciato.

9,5W LED  
 110-240V  
 2700K  
 CRI90  
 Gesture dimm

CE IP20   24V 1020lm  MacAdam Step 3

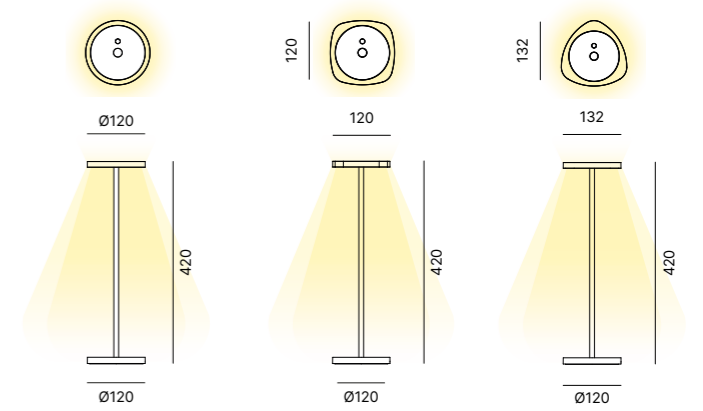

FINISH OPTIONS  
 FINITURE

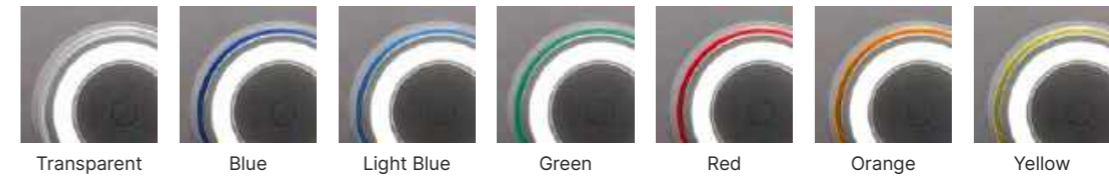

FRAME FINISH OPTIONS  
 FINITURE STRUTTURA



Black Goffratino

CD Led collection

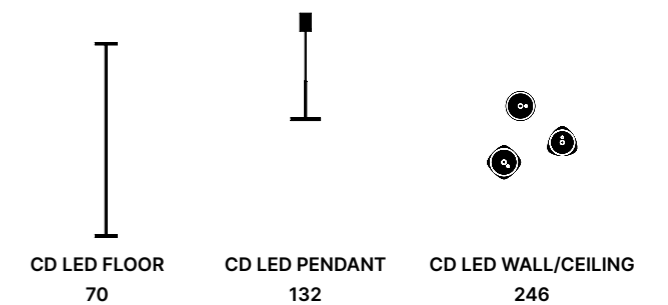







## Table lamp

## CD LED

Polycarbonate lamp diffuser with transparent or colored PMMA ring, powder coated metal frame.  
 Diffusore in policarbonato con anello in PMMA trasparente o colorato, struttura in metallo verniciato.

9,5W LED  
 110-240V  
 2700K  
 CRI90  
 Gesture dimm

CE IP20   24V 1020lm  MacAdam Step 3

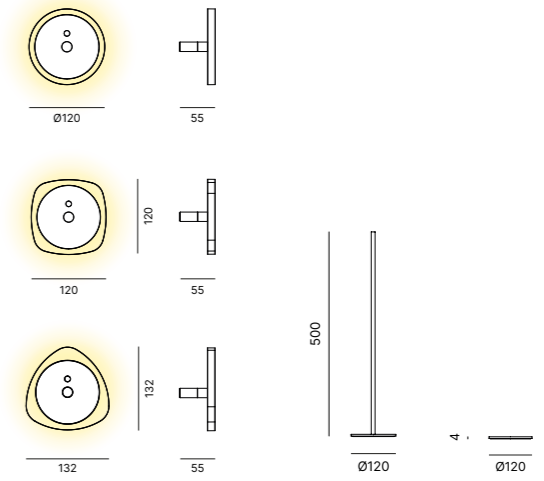

### FINISH OPTIONS FINITURE

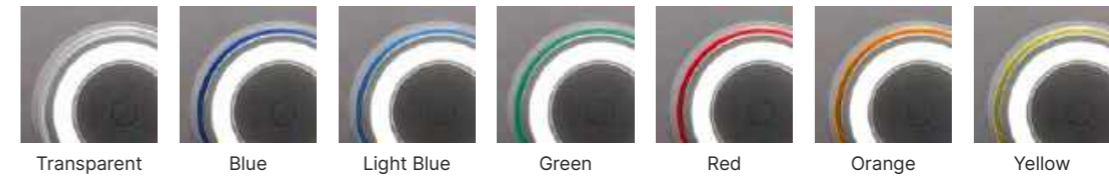

### FRAME FINISH OPTIONS FINITURE STRUTTURA



Black Goffratino

## CD Led collection

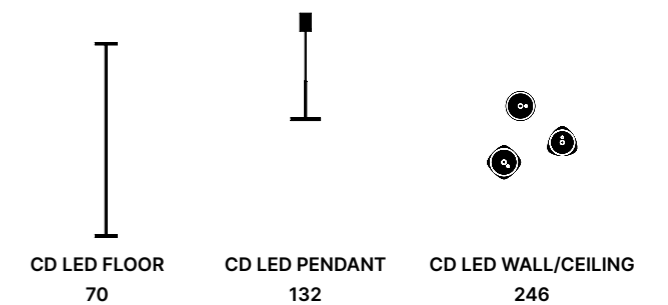



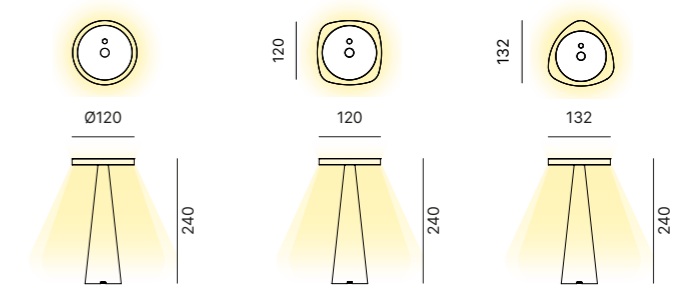

Table lamp

CD LED

Polycarbonate lamp diffuser with transparent or colored PMMA ring, powder coated metal frame.  
 Diffusore in policarbonato con anello in PMMA trasparente o colorato, struttura in metallo verniciato.

3W LED  
 110-240V  
 2700K  
 CRI90  
 Touch dimm



CE IP20 [Square icon] [LED icon] [MacAdam Step 3 icon]

FINISH OPTIONS  
 FINITURE



FRAME FINISH OPTIONS  
 FINITURE STRUTTURA



Black Goffratino

CD Led collection

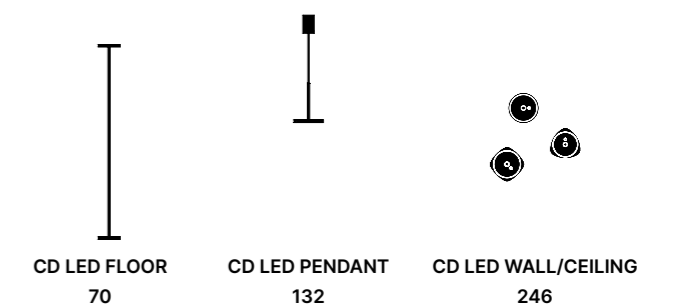





designed by Moreno De Giorgio

**Renewed imagination.  
Grace reinterprets the traditional  
shape of the lamp through  
original finishings, from the  
round and perforated base to the  
shade fabric: a highly suitable  
solution for residential interiors  
and executive business settings  
alike.**

Immaginario rinnovato.  
Grace reinterpreta la forma tradizionale della lampada attraverso  
finiture inedite, dal basamento circolare forato, fino al tessuto  
del paralume: una soluzione che ben si presta sia per ambienti  
residenziali sia per spazi di business direzionali.



TABLE LAMPS





## Table lamp

GRACE

Table lamp with powder coated metal frame, linen or cotton shade.

Lampada da tavolo con stelo in metallo verniciato, paralume in lino o cotone.

MAX 1XE27 100W  
220-240V  
ON-OFF | Dimmer

CE IP20 

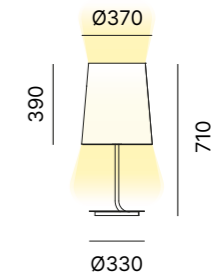

### SHADE FINISH OPTIONS FINITURE PARALUME



Natural Linen    Black Cotton

### FRAME FINISH OPTIONS FINITURE STRUTTURA



Black Goffratino    Gold    Bronze    Corten

## Grace collection

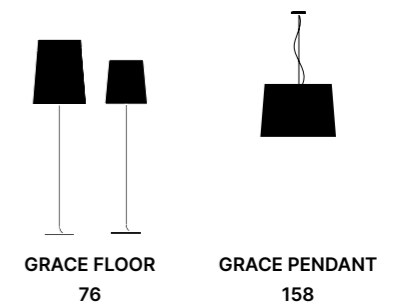

GRACE FLOOR  
76

GRACE PENDANT  
158



# HALF MOON

designed by Enrico Franzolini & Vicente García Jimenez

**Concrete style.**  
**Classical shapes and multi-faceted nature: Half Moon is the right table lamp for enhancing residential, business and hospitality settings.**  
**The stem can be customised in the colours black goffratino, bronze, gold and corten, for a precious touch.**

38

**Stile concreto.**

Forme classiche e natura poliedrica: Half Moon è la lampada da tavolo giusta per valorizzare spazi residenziali, business e hospitality. Lo stelo è personalizzabile nei colori nero goffratino, bronzo, oro e corten, per un tocco prezioso.



TABLE LAMPS



39





**The shade of Half Moon is made of linen or cotton and can be fitted with a neutral or coloured inner cover. Available tonalities combine with the light when on, warming the ambience of interiors.**

Il paralume di Half Moon è in lino o in cotone e si può dotare all'interno di un rivestimento coprente, neutro o colorato. Le tonalità a disposizione, abbinata alla luce accesa, scaldano l'atmosfera degli ambienti.





### Table lamp

## HALF MOON

Table lamp with powder coated metal frame, linen or cotton shade with white or colored inside.  
Lampada da tavolo con stelo in metallo verniciato, paralume in lino o cotone con interno coprente bianco o colorato.

MAX 1XE27 100W  
220-240V  
ON-OFF | Dimmer

CE IP20

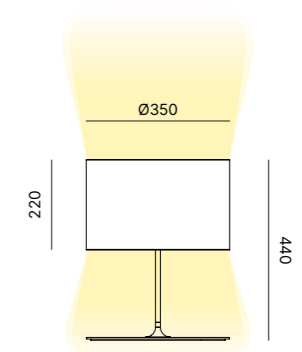

#### SHADE FINISH OPTIONS FINITURE PARALUME



Black Cotton White inside    Black Cotton Yellow inside    Black Cotton Orange inside    Black Cotton Fuchsia inside    Natural Linen White inside    Natural Linen Yellow inside    Natural Linen Orange inside    Natural Linen Fuchsia inside

#### FRAME FINISH OPTIONS FINITURE STRUTTURA

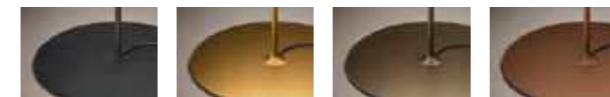

Black Goffratino    Gold    Bronze    Corten

### Half Moon collection

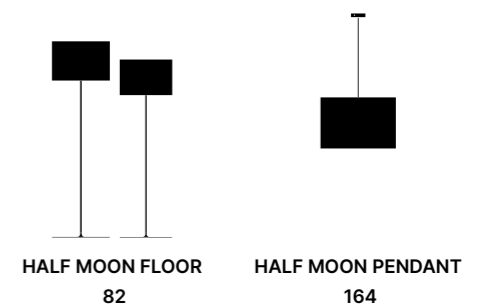



designed by Enrico Franzolini

**Technology and material.  
Designed for hospitality  
and residential interiors, Ola  
combines formal research  
and material, culminating  
in an iconic lamp featuring  
a painted metal stem and  
fibreglass shade.**

Tecnologia e materia.

Progettata per ambiti hospitality e residenziali, Ola è la sintesi di una ricerca formale e materiale: nasce così questa lampada iconica, con stelo in metallo verniciato e paralume in fibra di vetro.



TABLE LAMPS







## Table lamp

OLA

Table lamp with fibreglass shade and black powder coated metal frame.  
Lampada da tavolo con paralume in fibra di vetro, stelo in metallo verniciato nero.

MAX 1XE27 100W  
220-240V  
ON-OFF | Dimmer

CE IP20

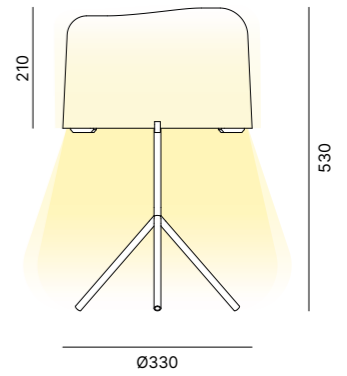

### SHADE FINISH OPTIONS FINITURE PARALUME



White  
fibreglass

Red  
fibreglass

Orange  
fibreglass

Gold  
fibreglass

Silver  
fibreglass

### FRAME FINISH OPTIONS FINITURE STRUTTURA



Black Goffratino

## Ola collection

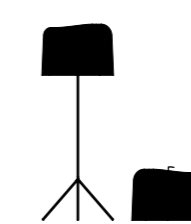

OLA FLOOR - 88  
OLA MOVE FLOOR - 94

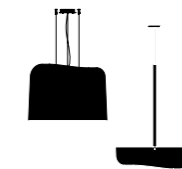

OLA PENDANT - 176  
OLA FLY PENDANT - 182



OLA SLIM WALL/CEILING  
264

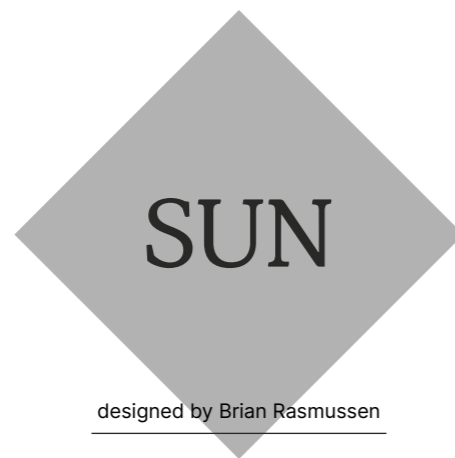

**Broken down light.  
Ideal for original and  
creative settings, Sun  
consists of a metal base  
and a shade available in 3  
tonalities, which fragments  
and reflects light, with no  
less than 96 fabric parts.**

**Luce scomposta.**  
Ideale per ambienti ricercati e creativi, Sun è formata da una base in metallo e un paralume, disponibile in 3 tonalità, che frammenta e riflette la luce, grazie alla lavorazione di 96 parti di tessuto.

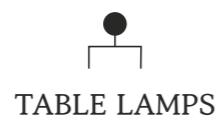





### Table lamp

### SUN

Table lamp with fabric shade and matt white powder coated metal frame.

Lampada da tavolo con paralume in tessuto e stelo in metallo verniciato bianco opaco.

MAX 1XE27 100W  
220-240V  
ON-OFF | Dimmer

CE IP20

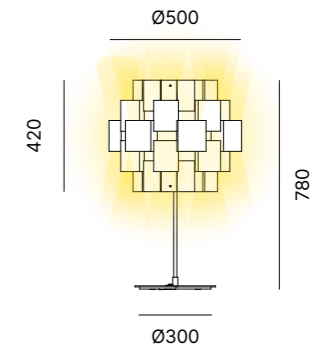

#### SHADE FINISH OPTIONS FINITURE PARALUME



White fabric    Black fabric    Red fabric

#### FRAME FINISH OPTIONS FINITURE STRUTTURA

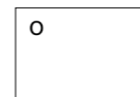

Matt White

### Sun collection

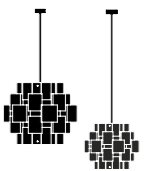

SUN PENDANT  
214

# Floor Lamps

Decorative Lighting



## Floor lamps



AFRA

AFRA FLOOR - 58



BABEL

BABEL FLOOR - 64



CD LED

CD LED FLOOR- 70



GRACE

GRACE FLOOR - 76



HALF MOON

HALF MOON FLOOR - 82

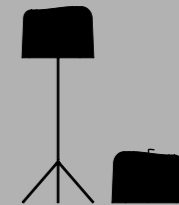

OLA

OLA FLOOR - 88  
OLA MOVE FLOOR - 94



WARM

WARM FLOOR - 100





**A globe of light.  
The aluminium structure  
culminates in a bubble  
of opaline glass light,  
customisable with a  
handmade fabric cover:  
Afra is the perfect lamp for  
refined and shared settings.**

**Globo di luce.  
La struttura in alluminio culmina in una bolla di  
luce in vetro opalino, personalizzabile con una  
cuffia in tessuto fatta a mano: Afra è la lampada  
perfetta per ambienti raffinati e condivisi.**



AFRA floor lamp | Matt White acid-etched glass shade and Black Goffratino frame  
ABBEY sofa | I01/519 fabric and Umbra Grey feet



## Floor lamp

AFRA

Floor lamp with white acid etched blown glass shade and powder coated metal frame.

Lampada da terra con paralume in vetro soffiato acidato bianco e base in metallo verniciato.

MAX 1XE27 100W  
220-240V  
ON-OFF | Dimmer

CE IP20 

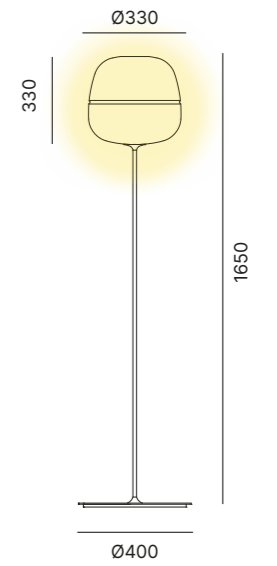

### SHADE FINISH OPTIONS FINITURE PARALUME



White acid-etched glass

### CAP (optional) CUFFIA (opzionale)



Beige

Black

### FRAME FINISH OPTIONS FINITURE STRUTTURA

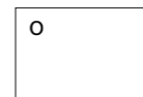

Matt White



Black Goffratino



Gold



Bronze

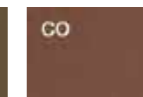

Corten

## Afra collection

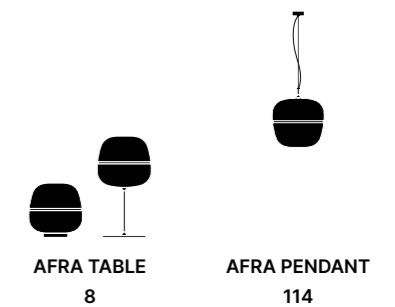

AFRA TABLE  
8

AFRA PENDANT  
114





**Ancient genesis.  
The shade is inspired by  
the legendary unfinished  
tower of Babel and replicates  
its ascending shape in the  
fabric shade, supported by  
a metal tripod: a suitable  
design for public and private  
settings alike.**

Genesi antica.

La lampada si ispira alla mitica torre incompiuta di Babele e ne replica la forma ascendente nel paralume in tessuto, poggiato su un treppiede in metallo: un design adatto per spazi pubblici e privati.



FLOOR LAMPS







## Floor lamp

## BABEL

Floor lamp with honeycomb fabric shade and powder coated metal frame.  
Paralume in tessuto a nido d'ape, base in metallo verniciato.

MAX 3XE27 60W  
220-240V  
ON-OFF | Dimmer

CE  IP20

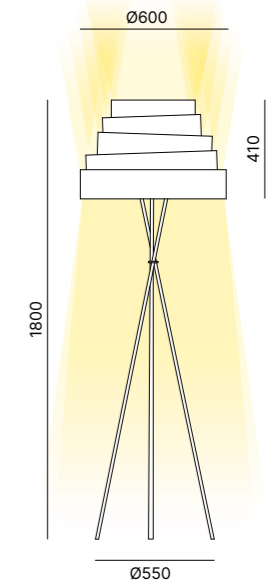

### SHADE FINISH OPTIONS FINITURE PARALUME



White

Black

### FRAME FINISH OPTIONS FINITURE STRUTTURA

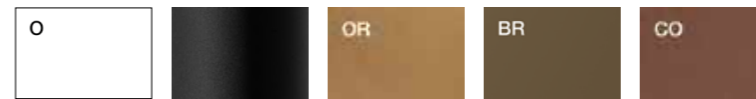

Matt White

Black Goffratino

Gold

Bronze

Corten

## Babel collection



BABEL PENDING  
120



**Flexible identity.  
Ideal as a reading lamp or  
as an ambience-setting  
light point for domestic and  
hospitality interiors, CD Led  
features an minimalistic and  
customisable design that  
characterises all settings  
with a tailored style.**

**Identità flessibile.  
Ideale come lampada da lettura o come punto luce  
d'atmosfera per spazi domestici e ricettivi,  
CD Led ha un design minimal e personalizzabile, per  
caratterizzare ogni ambiente con uno stile su misura.**



FLOOR LAMPS

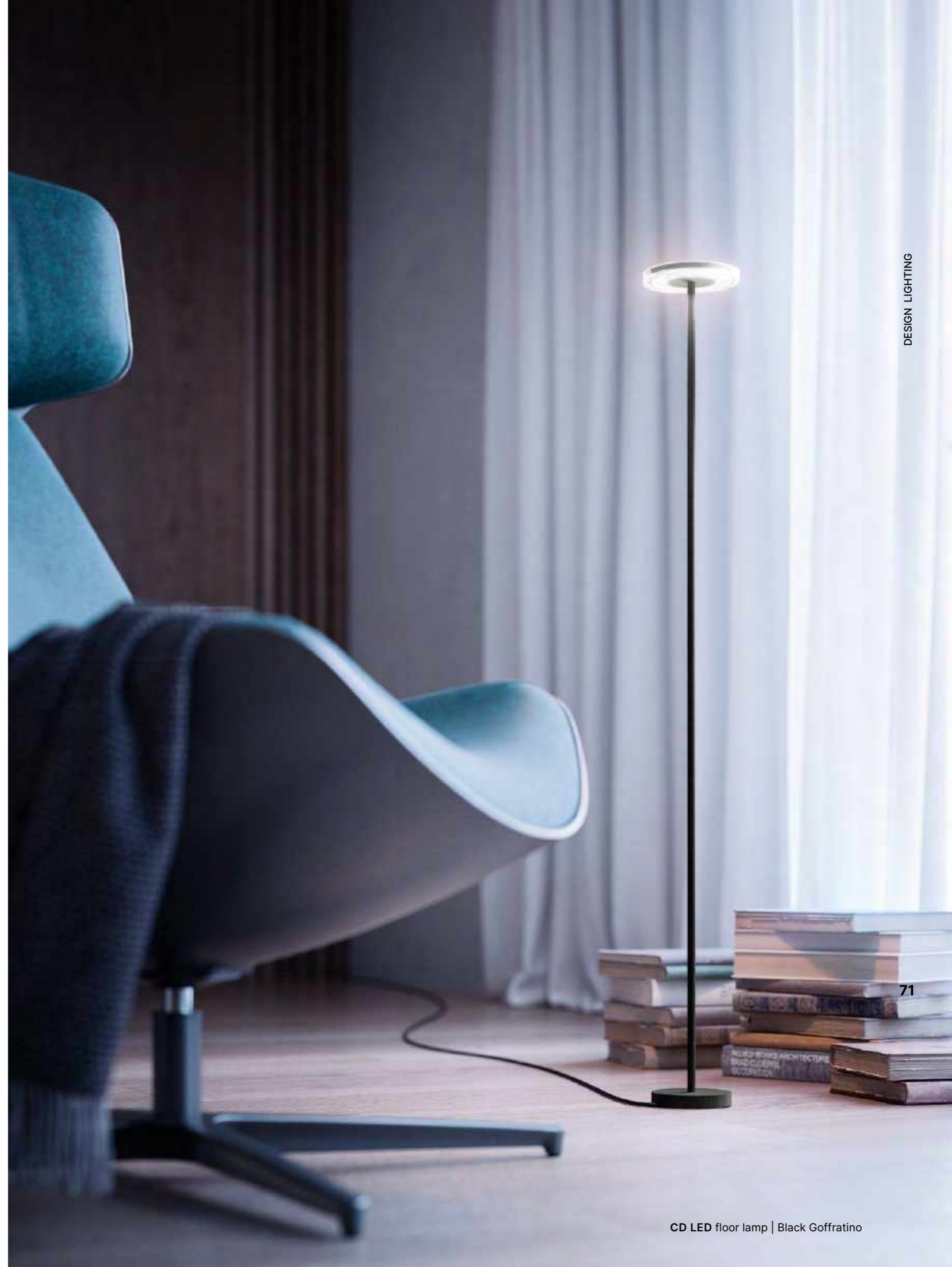



Floor lamp

CD LED

Polycarbonate lamp diffuser with transparent or colored PMMA ring, powder coated metal frame.  
 Diffusore in policarbonato con anello in PMMA trasparente o colorato, struttura in metallo verniciato.

9,5W LED  
 110-240V  
 2700K  
 CRI90  
 Gesture dimm

CE IP20 LED 24V 1020lm MacAdam Step 3

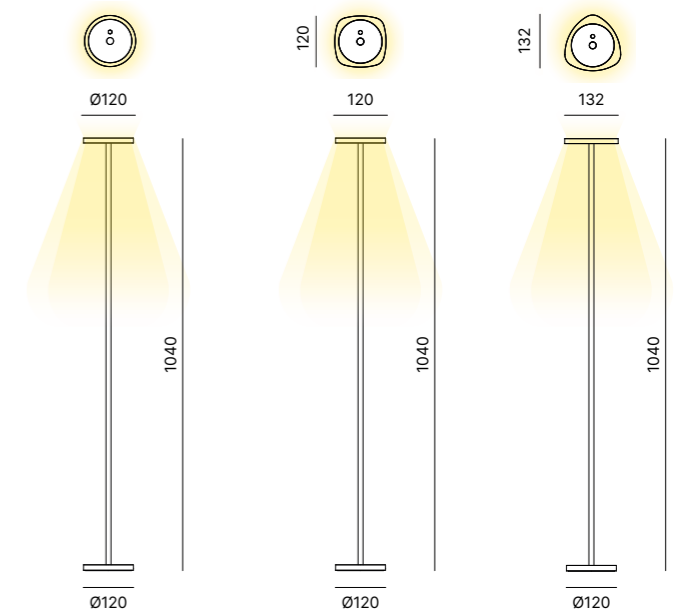

FINISH OPTIONS  
 FINITURE

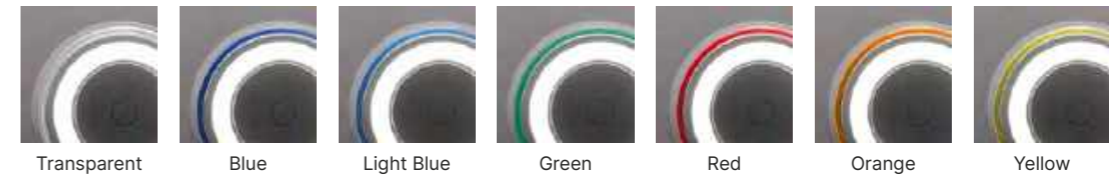

FRAME FINISH OPTIONS  
 FINITURE STRUTTURA



Black Goffratino

CD Led collection

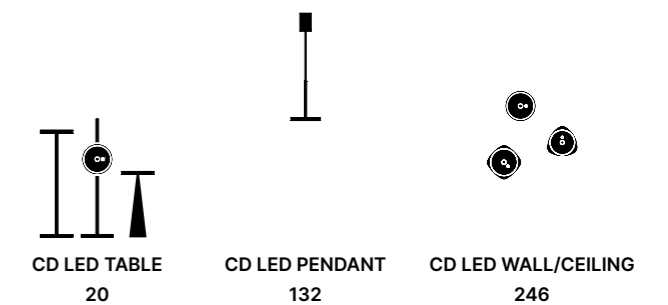





designed by Moreno De Giorgio

**Natural aesthetics.  
Grace exquisitely adapts to  
different settings, thanks  
to its two versions, small  
and big. Its classical shapes  
are exalted by original  
finishings, like the natural  
linen or black cotton shade.**

**Estetica naturale.**

Grace si adatta con garbo a diversi ambienti, grazie alle due versioni, piccola e grande, e alle forme classiche esaltate da finiture ricercate, come il paralume in lino naturale o cotone nero.



FLOOR LAMPS







## Floor lamp

GRACE

Floor lamp with powder coated metal frame, linen or cotton shade.

Lampada da terra con stelo in metallo verniciato, paralume in lino o cotone.

### Grace small

MAX 1XE27 100W  
220-240V  
ON-OFF | Dimmer

### Grace

MAX 3XE27 60W  
220-240V  
ON-OFF | Dimmer

CE IP20

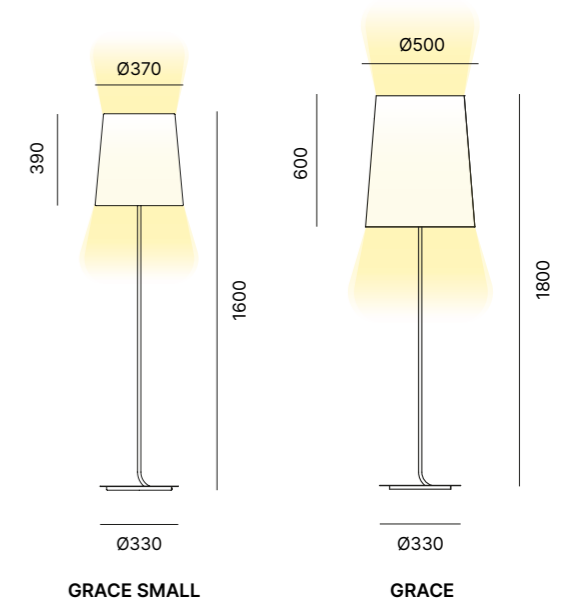

### SHADE FINISH OPTIONS FINITURE PARALUME



Natural Linen Black Cotton

### FRAME FINISH OPTIONS FINITURE STRUTTURA



Black Goffratino Gold Bronze Corten

## Grace collection

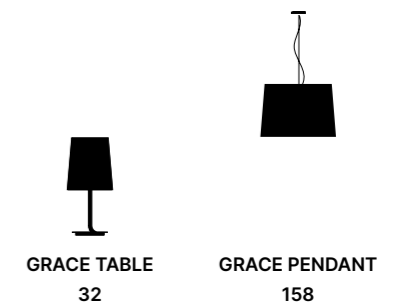

GRACE TABLE  
32

GRACE PENDANT  
158

# HALF MOON

designed by Enrico Franzolini & Vicente García Jimenez

**Timelessly classic.  
Half Moon is the perfect  
lamp for all shared spaces:  
it is ideal next to armchairs,  
sofas and ottomans and can  
be customised with different  
colour options. It is available in a  
big or small version, to enhance  
interiors of different sizes.**

Classico attuale.

Half Moon è la lampada perfetta per qualsiasi spazio di condivisione: ideale accanto a poltrone, divani e pouf, è personalizzabile nei colori e disponibile in versione grande o piccola, per valorizzare ambienti di diversa metratura.



FLOOR LAMPS

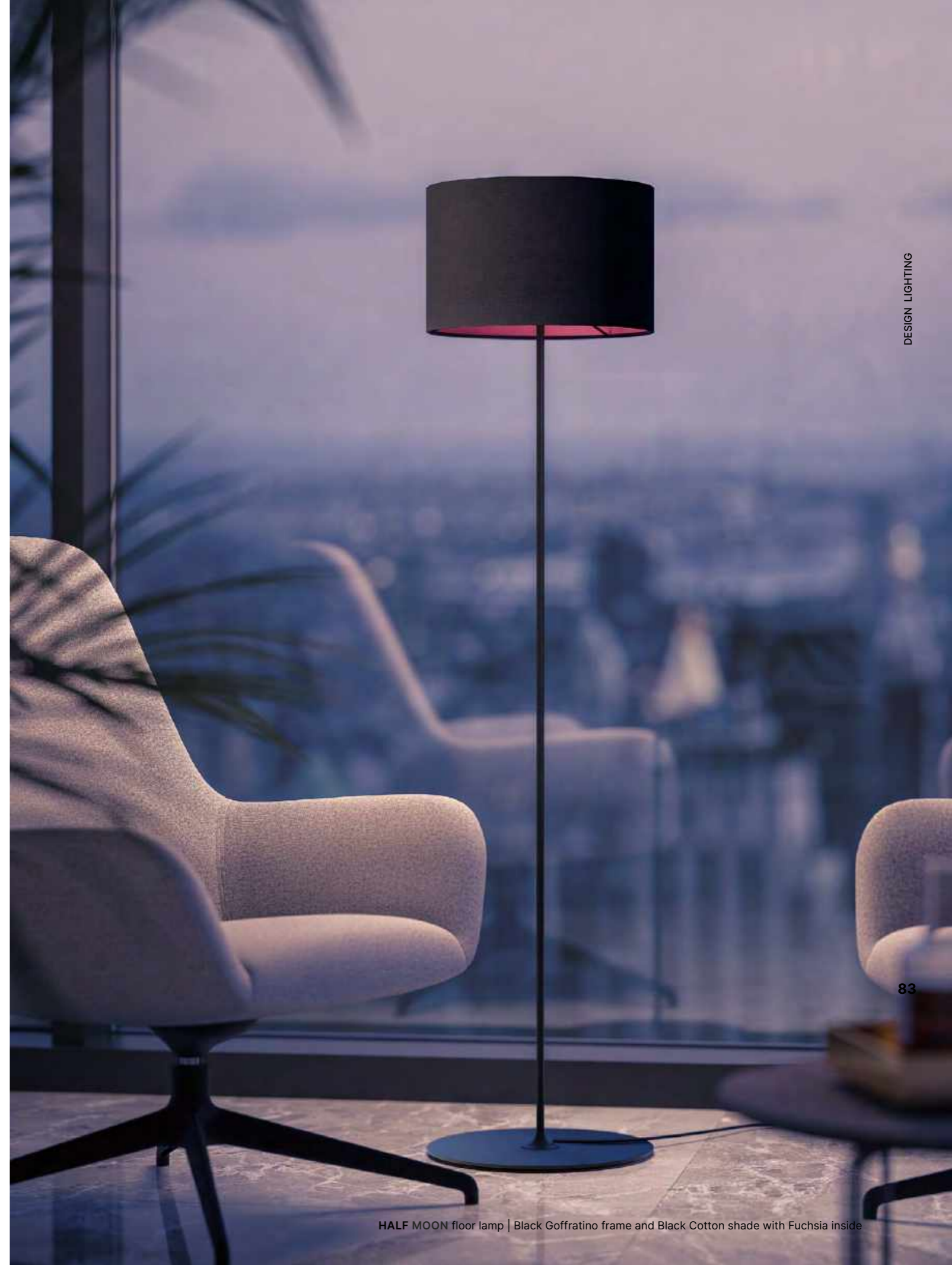



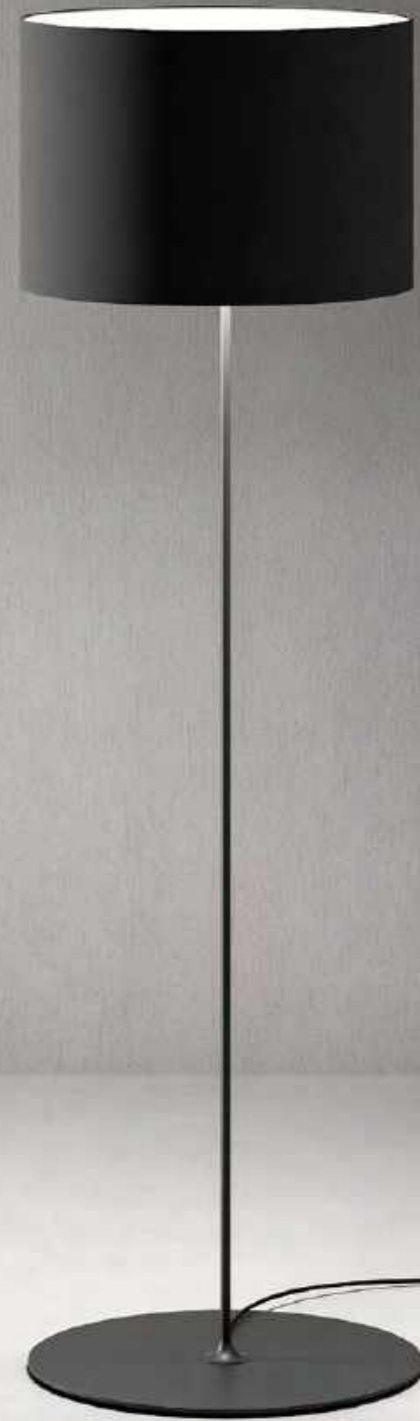

Floor lamp

HALF MOON

Floor lamp with powder coated metal frame, linen or cotton shade with white or colored inside.  
Lampada da terra con stelo in metallo verniciato, paralume in lino o cotone con interno coprente bianco o colorato.

**Half Moon small**  
MAX 1XE27 100W  
220-240V  
ON-OFF | Dimmer

**Half Moon**  
MAX 3XE27 60W  
220-240V  
ON-OFF | Dimmer

CE IP20

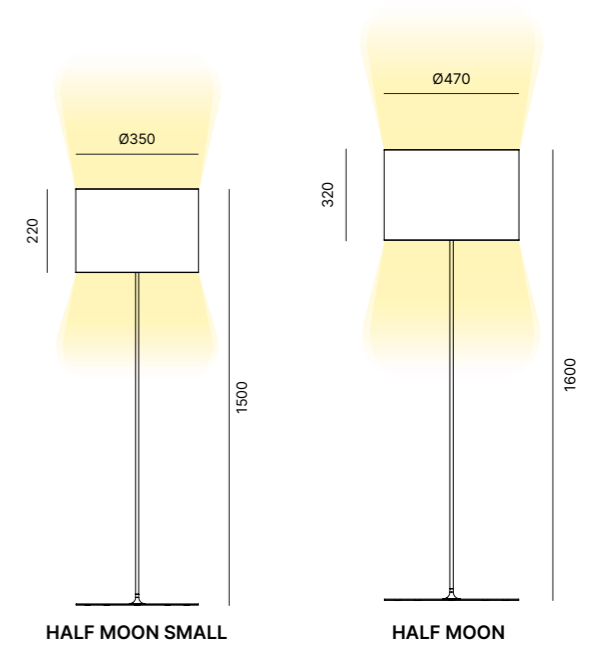

SHADE FINISH OPTIONS  
FINITURE PARALUME



FRAME FINISH OPTIONS  
FINITURE STRUTTURA



Half Moon collection

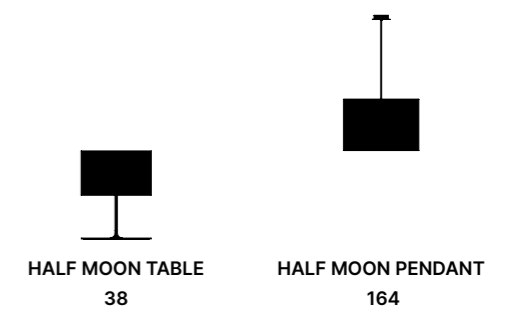





**Materialised sensation.  
Original materials and  
unprecedented shapes  
interpret a new concept  
of lighting. Ola is the floor  
lamp that turns light into  
ambience, thanks to the  
fibreglass shade available  
in five colours.**

**Sensazione materializzata.  
Materiali inediti e forme originali interpretano un nuovo concetto di  
illuminazione: Ola è la lampada da terra capace di trasformare la luce in  
atmosfera, grazie a cinque colorazioni del paralume in fibra di vetro.**



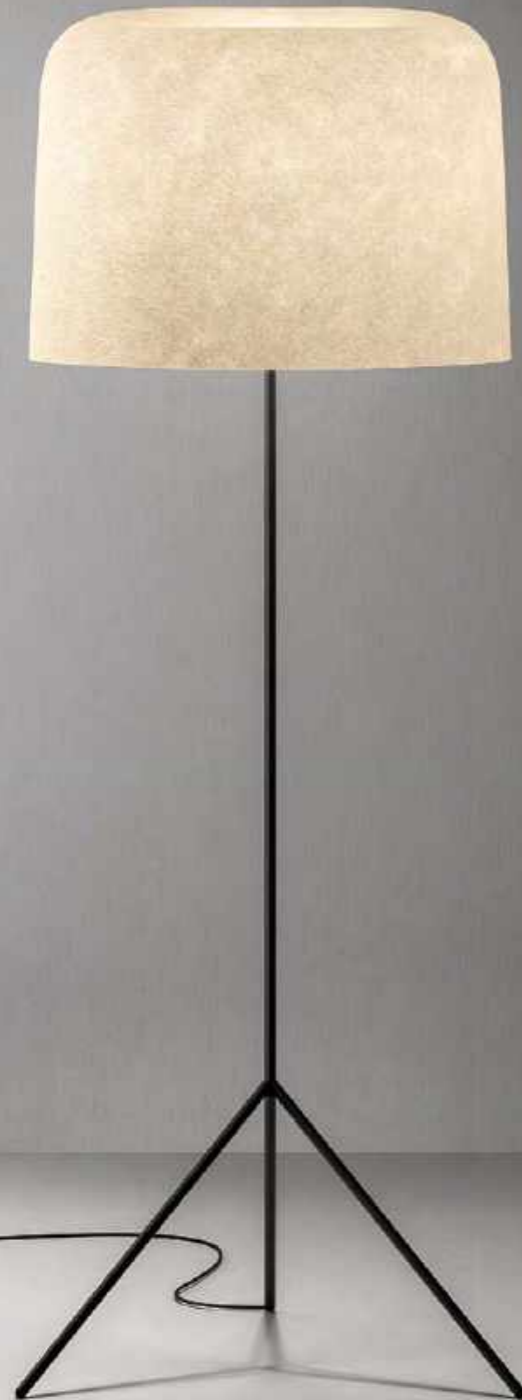

## Floor lamp

## OLA

Floor lamp with fibreglass shade and black powder coated metal frame.

Lampada da terra con paralume in fibra di vetro, stelo in metallo verniciato nero.

MAX 3XE27 60W  
220-240V  
ON-OFF | Dimmer

CE IP20 

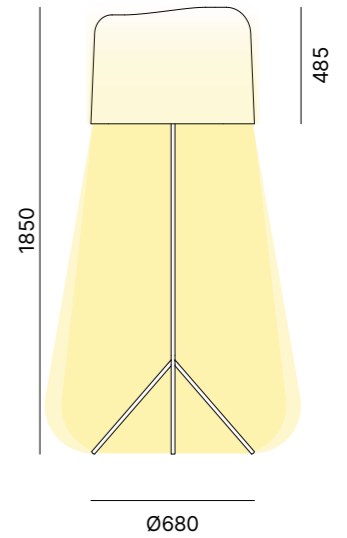

### SHADE FINISH OPTIONS FINITURE PARALUME



White fibreglass

Red fibreglass

Orange fibreglass

Gold fibreglass

Silver fibreglass

### FRAME FINISH OPTIONS FINITURE STRUTTURA



Black Goffratino

## Ola collection



OLA TABLE  
44



OLA MOVE FLOOR  
94

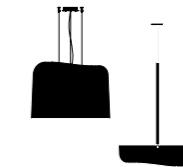

OLA PENDANT - 176  
OLA FLY PENDANT - 182



OLA SLIM WALL/CEILING  
264



# OLA MOVE

designed by Enrico Franzolini

**Stylish movement.  
Warm, inviting and diffused  
lighting. Ola Move is the floor  
lamp available in five colours,  
for furnishing professional  
and residential interiors. It can  
be moved anywhere thanks to  
the practical metal handle.**

**Movimento di stile.**

**Illuminazione calda, accogliente e diffusa: Ola Move è la lampada da terra disponibile in cinque colori per arredare ambienti professionali e residenziali. Si trasporta ovunque grazie alla pratica maniglia in metallo.**



FLOOR LAMPS

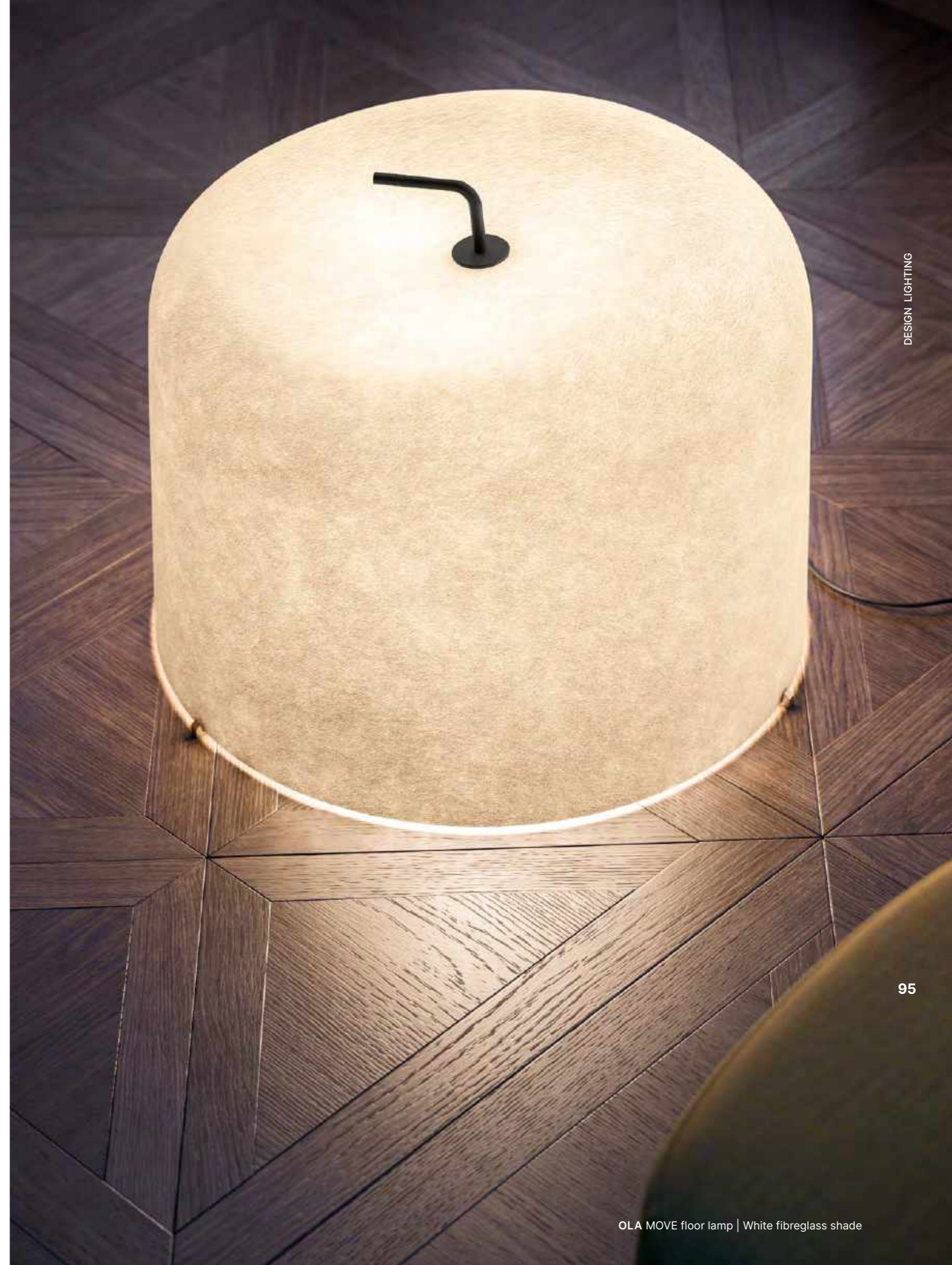





### Floor lamp

## OLA MOVE

Floor lamp with fibreglass shade and black powder coated metal handle.

Lampada da terra con paralume in fibra di vetro, maniglia in metallo verniciato nero.

MAX 3XE27 60W  
220-240V  
ON-OFF | Dimmer

CE IP20

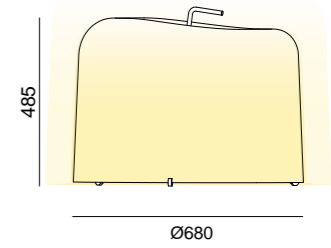

#### SHADE FINISH OPTIONS FINITURE PARALUME



White fibreglass   Red fibreglass   Orange fibreglass   Gold fibreglass   Silver fibreglass

#### FRAME FINISH OPTIONS FINITURE STRUTTURA



Black Goffratino

### Ola collection

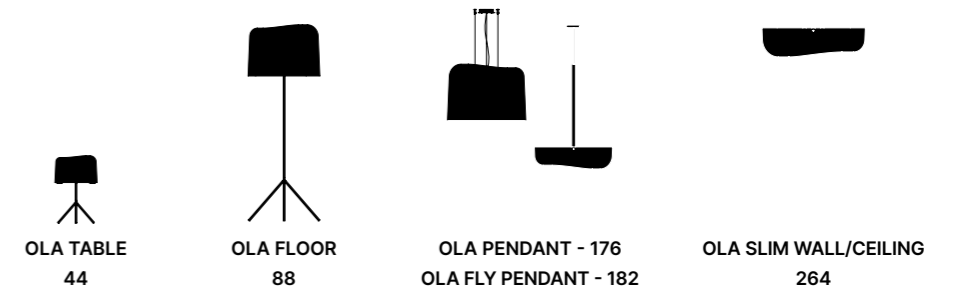





**Enlightened mood.  
Available in an indoor and  
outdoor version, with decorative  
fabric mesh upon request, Warm  
characterises settings with  
its soft and undulating profile,  
providing lighting thanks to an  
internal diffuser.**

**Mood luminoso.  
Disponibile in versione indoor e outdoor, con rete  
decorativa in tessuto su richiesta, Warm caratterizza gli  
spazi con il suo profilo morbido e ondulato e li illumina  
grazie a un diffusore interno.**





## Floor lamp

## WARM

Floor lamp with white polyethylene shade and zinc-plated steel base. Indoor and outdoor version available.  
Lampada da terra con diffusore in polietilene bianco e base in metallo zincato. Disponibile in versione indoor e outdoor.

MAX 1XE27 100W  
220-240V  
ON-OFF | Dimmer

CE IP20 IP68 

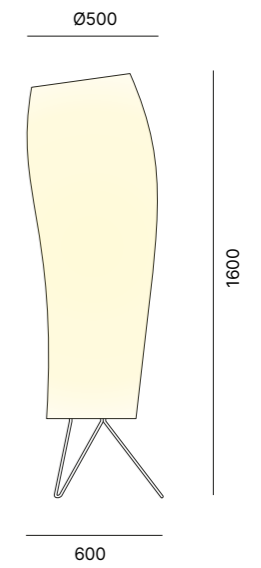

### SHADE FINISH OPTIONS FINITURE PARALUME



White  
polyethylene

### MESH (optional) RETE (opzionale)

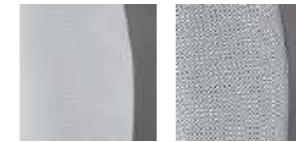

White

Black

### FRAME FINISH OPTIONS FINITURE STRUTTURA



Black Goffratino



# Pendant Lamps

Decorative Lighting



## Pendant lamps



ADD

ADD PENDANT - 108



AFRA

AFRA PENDANT - 114



BABEL

BABEL PENDANT - 120



BLONDE

BLONDE PENDANT - 126



CD LED

CD LED PENDANT - 132



DRINK

DRINK PENDANT - 140

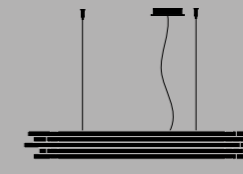

ESCAPE

ESCAPE PENDANT - 146



GOUT

GOUT PENDANT - 152



GRACE

GRACE PENDANT - 158



HALF MOON

HALF MOON PENDANT - 164



MIRAGE

MIRAGE PENDANT - 170

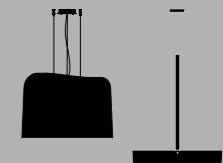

OLA

OLA PENDANT - 176  
OLA FLY PENDANT - 182



PIPES

PIPES PENDANT - 188

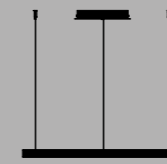

PLANET

PLANET PENDANT - 194



SLICE

SLICE PENDANT - 202

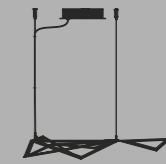

STARLIGHT

STARLIGHT PENDANT - 208



SUN

SUN PENDANT - 214

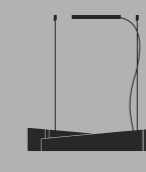

SVEVA

SVEVA PENDANT - 220



TUBE

TUBE PENDANT - 226  
TUBE MICRO PENDANT - 232

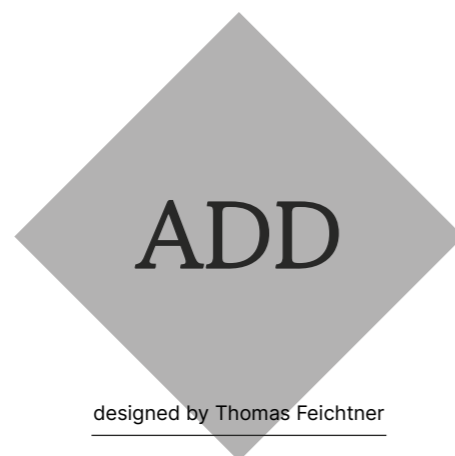

designed by Thomas Feichtner

**A sprinkle of light.  
Ideal for hospitality and  
business settings, Add is a  
play of reflections: the circular  
opening at the top of the  
ceramic shade generates a  
dynamism between the white  
interior and the varnished  
colour exterior.**

Pioggia di luce.

Ideale per spazi ricettivi e business, Add è un gioco di riflessi: l'apertura circolare sulla sommità del paralume in ceramica crea dinamismo tra l'interno bianco e l'esterno rifinito in smalto colorato.



PENDANT LAMPS







## Pendant lamp

ADD

Pendant lamp with pottery shade in different colors with glossy white inside.

Lampada a sospensione con paralume in ceramica in varie finiture con interno smaltato bianco lucido.

MAX 1XE27 100W  
220-240V  
T/fase

CE IP20 

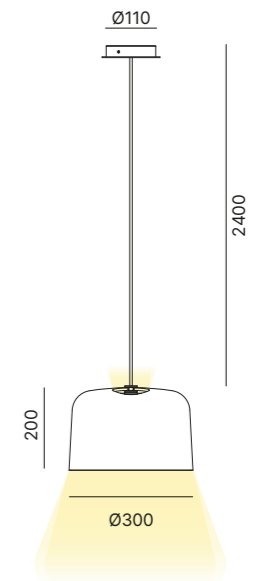
SHADE FINISH OPTIONS  
FINITURE PARALUMECEILING ROSE  
ROSONE

Matt White

DETAILS  
DETTAGLI



**Resplendent pearl.  
Afra is an elegant  
ambience-setting lamp:  
the blown glass sphere  
embraces a hand-woven  
cover, available in unique  
textures that filter light in  
different ways.**

**Perla splendente.  
Afra è una lampada elegante e d'atmosfera: il globo di vetro  
soffiato accoglie una cuffia tessuta a mano, disponibile in  
texture uniche che filtrano la luce in modi sempre diversi.**



PENDANT LAMPS







## Pendant lamp

AFRA

Pendant lamp with white acid etched blown glass shade and powder coated metal frame.

Lampada a sospensione con paralume in vetro soffiato acidato bianco e struttura in metallo verniciato.

MAX 1XE27 100W  
220-240V  
T/fase

CE IP20 

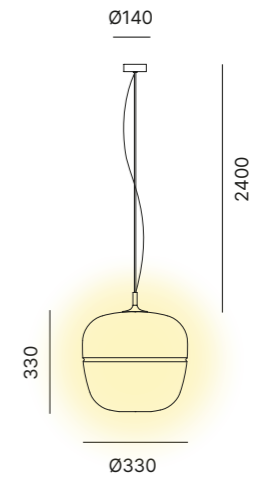
SHADE FINISH OPTIONS  
FINITURE PARALUME

White acid-etched glass

CAP (optional)  
CUFFIA (opzionale)

Beige



Black

CEILING ROSE  
ROSONE

Matt White

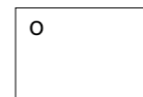
FRAME FINISH OPTIONS  
FINITURE STRUTTURA

Matt White



Black Goffratino



Gold



Bronze



Corten

## Afra collection

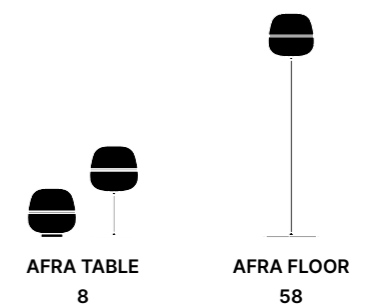



**Legendary allure.  
The honeycomb fabric  
shade of the Babel lamp  
is inspired by the shape  
of the biblical tower, in an  
enveloping spiral around  
the white painted metal  
support.**

**Fascino leggendario.  
Il paralume in tessuto a nido d'ape della lampada Babel si ispira  
alla forma della torre biblica, in una spirale che si avvolge per  
raggiungere il supporto in metallo verniciato bianco.**



PENDANT LAMPS





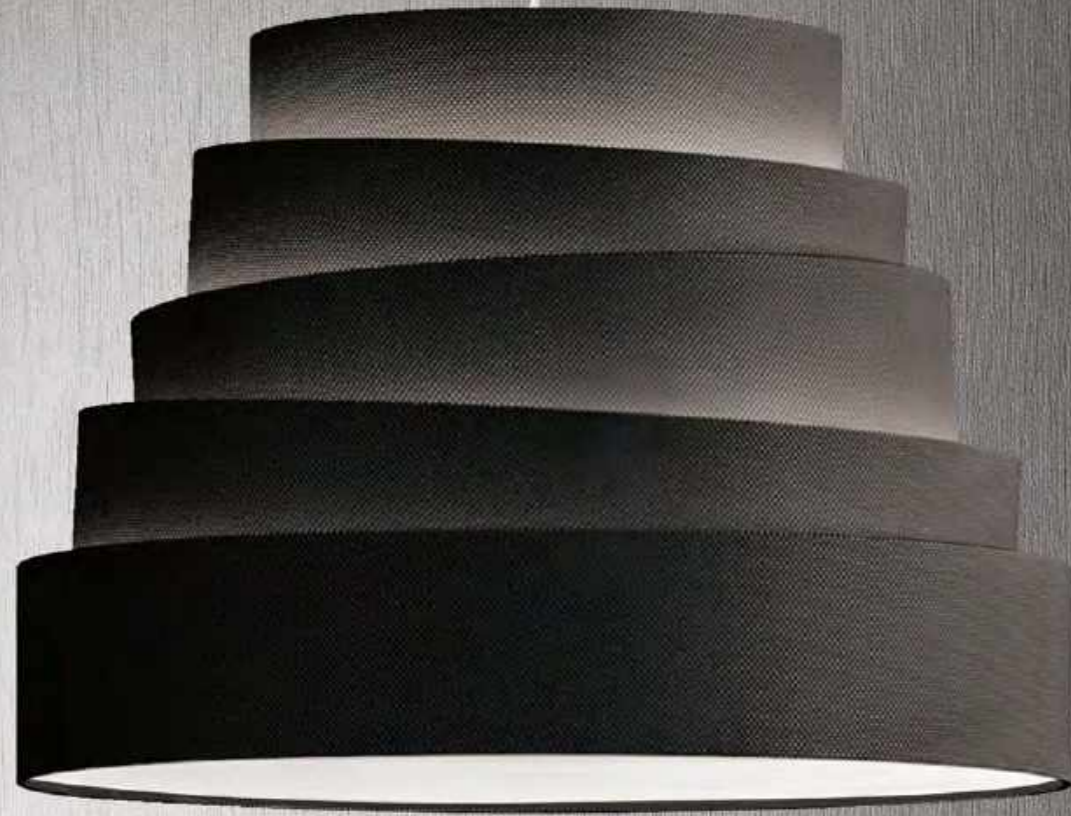

### Pendant lamp

# BABEL

Pendant lamp with honeycomb fabric shade.  
Lampada a sospensione con paralume in tessuto a nido d'ape.

MAX 3XE27 60W  
220-240V  
T/fase

CE IP20

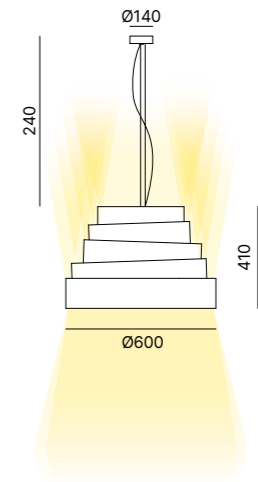

#### SHADE FINISH OPTIONS FINITURE PARALUME



White

Black

#### CEILING ROSE ROSONE



Matt White

### Babel collection



BABEL FLOOR  
64



**Eclectic imagination.  
The trapezoidal shape  
decisively characterises  
settings: in the kitchen,  
meeting rooms or open  
spaces, Blonde is the ceiling  
lamp that is versatile both  
in terms of use and the  
customisation of its finishings.**

Fantasia eclettica.

La forma trapezoidale caratterizza gli ambienti con decisione: in cucina, in sala riunioni o in open space, Blonde è la lampada a soffitto versatile nell'uso e nella personalizzazione delle finiture.



TABLE LAMPS







## Pendant lamp

## BLONDE

Pendant lamp in powder coated aluminium.  
Lampada a sospensione in alluminio verniciato.

Blonde 126	Blonde 166	Blonde 246
84W LED	113W LED	171W LED
7000 lm	9400 lm	14200 lm
110-240V	110-240V	110-240V
2700/3000K	2700/3000K	2700/3000K
CRI80	CRI80	CRI80
All in one	All in one	All in one

CE IP20   24V  MacAdam Step 3

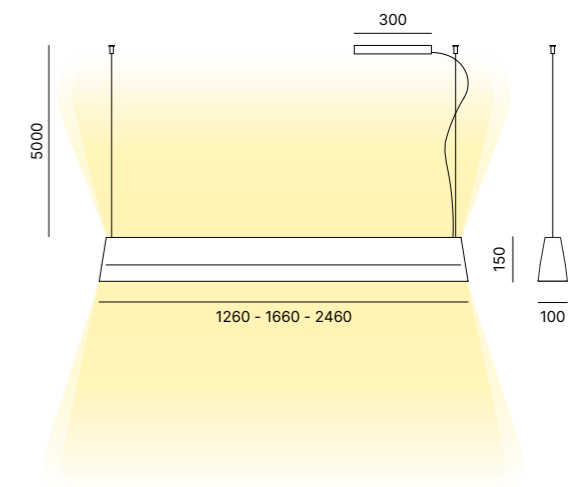
LAMP FINISH OPTIONS  
FINITURE LAMPADA

Matt White

Brushed  
AlluminiumBlack  
Goffratino

Gold

Bronze

Corten

CEILING ROSE  
ROSONE

Matt White



**Luminous arrangements.  
Minimalistic design,  
customisation possibilities  
and adjustable intensity: CD  
Led combines contemporary  
aesthetics and functionality  
to create large dynamic  
compositions, ideal for business,  
living and hospitality contexts.**

**Accordi luminosi.**

Design minimale, possibilità di personalizzazione e intensità regolabile: CD Led unisce estetica contemporanea e massima funzionalità per creare composizioni dinamiche di grandi dimensioni, ideali per contesti business, living e hospitality.



PENDANT LAMPS







Pendant lamp

CD LED

Pendant lamp with down or up light. Polycarbonate lamp diffuser with transparent or colored PMMA ring.

Lampada da sospensione a luce diretta o indiretta. Diffusore in policarbonato con anello in PMMA trasparente o colorato, struttura in metallo verniciato.

9,5W LED  
110-240V  
2700K  
CRI90  
ON-OFF | T-fase

CE IP20 LED 24V 1020lm MacAdam Step 3

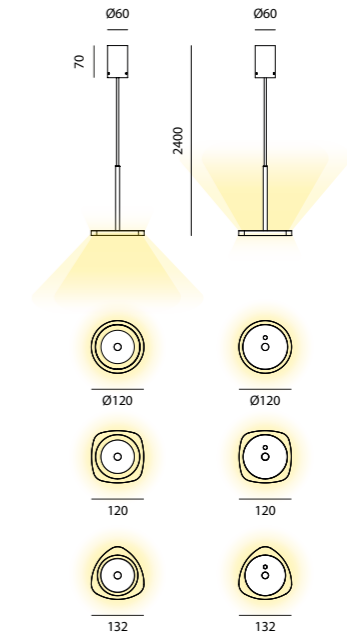

FINISH OPTIONS  
FINITURE



FRAME FINISH OPTIONS  
FINITURE STRUTTURA



Black Goffratino

CD Led collection

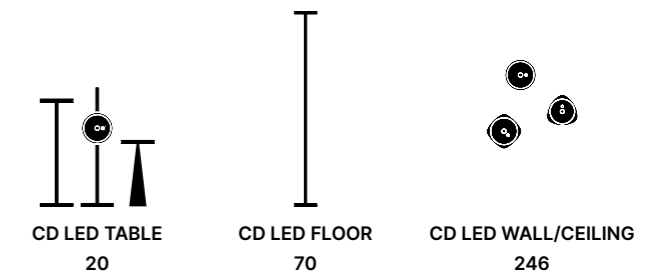



designed by Enrico Franzolini & Vicente García Jimenez

**A toast to light.  
Perfect for restaurants,  
clubs, wineries and hotel  
lobbies, Drink is a refined  
and original lighting  
solution: its aluminium  
upside down chalice  
shape is available in five  
different colours.**

Brindisi di luce.

Perfetta per ristoranti, club, enoteche e hall d'albergo,  
Drink è una soluzione di illuminazione raffinata e  
originale: la sua forma in alluminio a calice rovesciato è  
disponibile in cinque colorazioni.



PENDANT LAMPS

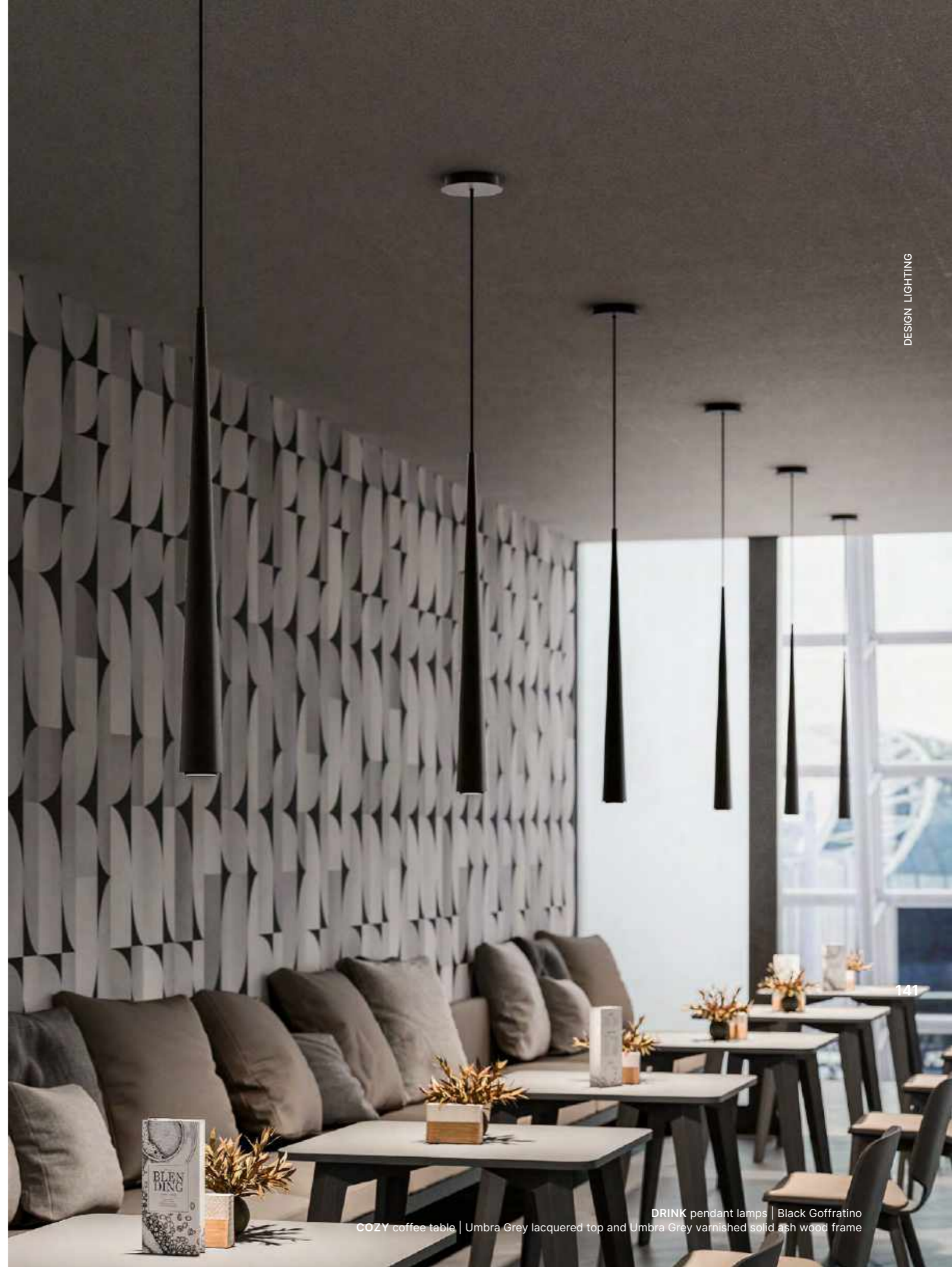





Pendant lamp

DRINK

Pendant lamp in powder coated aluminium.  
Lampada a sospensione in alluminio verniciato.

4W LED  
220-240V  
2700K  
CRI90  
T/fase | DALI/Push dimm

CE IP20 LED 45-60° 500lm MacAdam Step 3

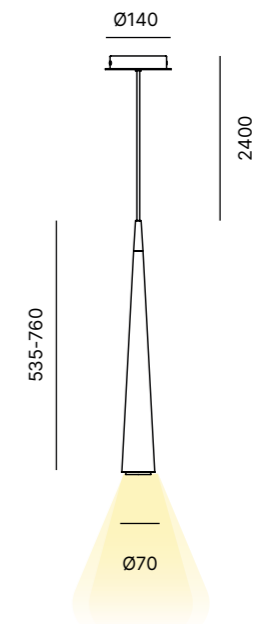

LAMP AND CEILING ROSE FINISH OPTIONS  
FINITURE LAMPADA E ROSONE



REFLECTOR FINISH OPTIONS  
FINITURE RIFLETTORE



Drink collection



DRINK CEILING  
252



**Kinetic lighting.**  
**The design of Escape embraces opposites: static and dynamic, light and shade, parallel and perpendicular. The lamp is a formal and conceptual synthesis and can be customised with different colour options for lighting shared settings.**

illuminazione cinetica.  
 Il design di Escape contiene gli opposti: statico e dinamico, luce e ombra, parallelo e perpendicolare. La lampada è una sintesi formale e concettuale, personalizzabile nei colori, per illuminare ambienti condivisi.



PENDANT LAMPS

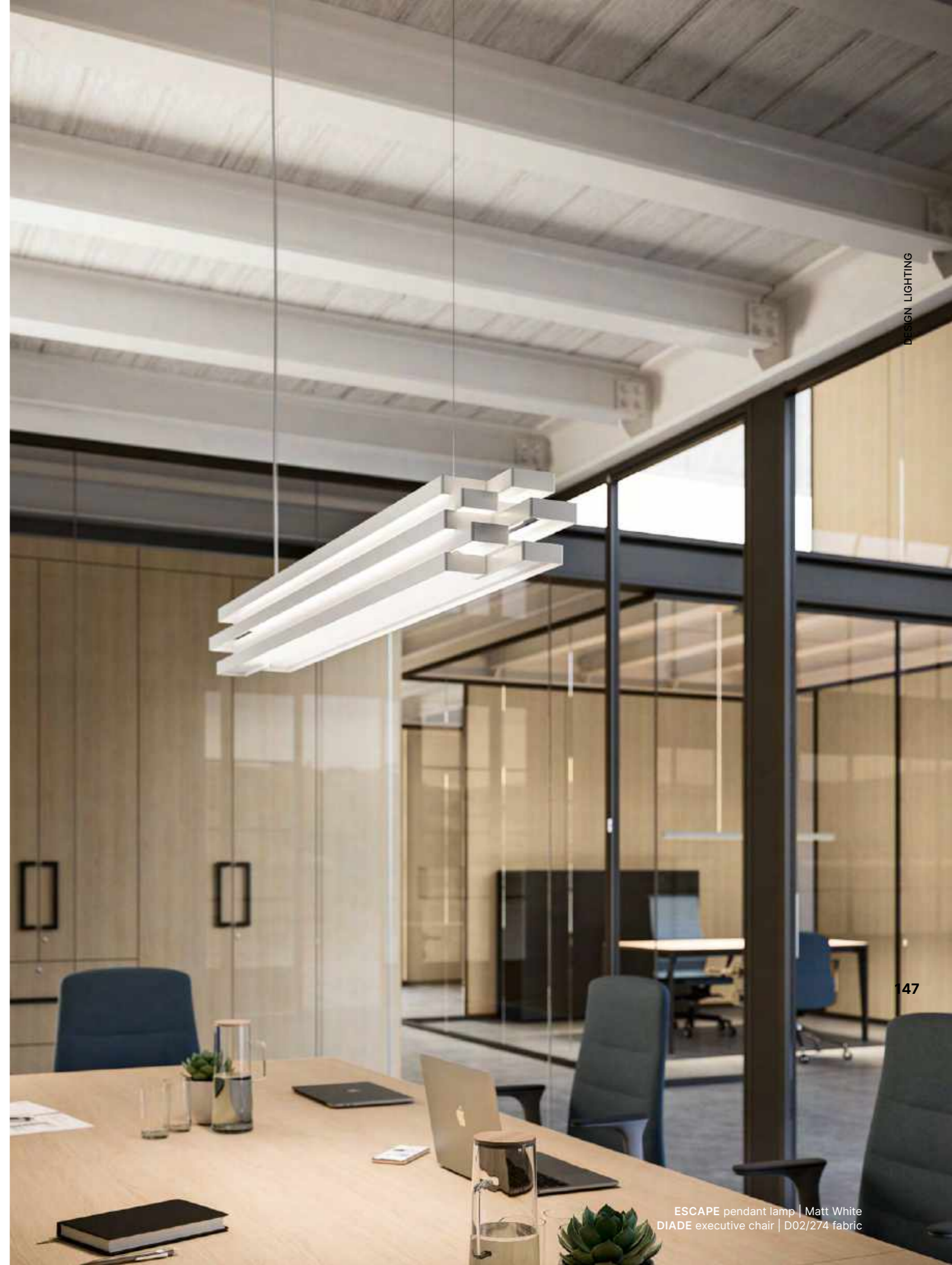





### Pendant lamp

## ESCAPE

Pendant lamp in powder coated aluminium.  
Matt methacrylate diffuser.  
Lampada a sospensione in alluminio verniciato.  
Diffusore in metacrilato opalino.

45,2W LED  
2700K  
CRI90  
ON-OFF | DALI/Push dimm

CE IP20 LED 5760lm MacAdam Step 3

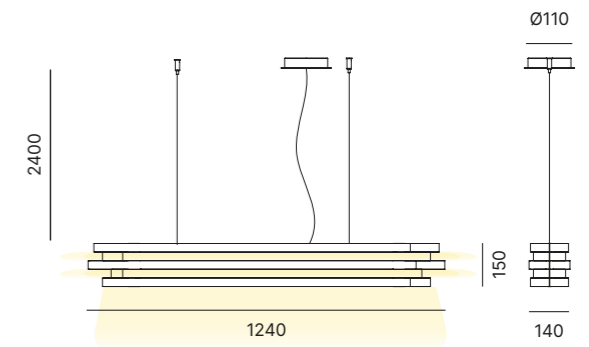

#### LAMP FINISH OPTIONS FINITURE LAMPADA

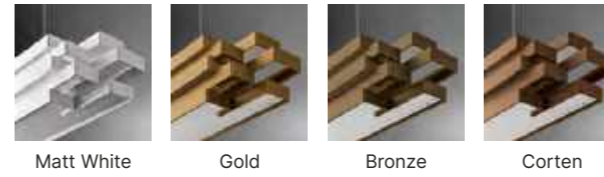

Matt White

Gold

Bronze

Corten

### Escape collection



ESCAPE WALL  
258



designed by Enrico Franzolini

**Natural elements.  
Gout draws inspiration from  
the shape of a water drop: the  
delicate blown glass diffuses  
a liquid light and appears  
crystallised in the act of falling,  
despite being firmly anchored to  
the ceiling by a painted metal rod.**

**Elementi naturali.**

Gout prende ispirazione dalla forma di una goccia d'acqua: il vetro soffiato, delicatissimo, diffonde una luce liquida e sembra cristallizzato nell'atto di cadere, mentre è saldamente ancorato al soffitto da un'asta in metallo verniciato.



PENDANT LAMPS







## Pendant lamp

GOUT

Pendant lamp with blown glass diffuser. Powder coated metal stem and ceiling rose.  
Lampada a sospensione con diffusore in vetro soffiato. Asta e rosone in metallo verniciato.

MAX 1XE27 100W  
220-240V  
T/fase

CE IP20 

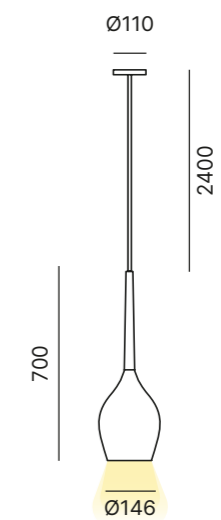
LAMP FINISH OPTIONS  
FINITURE LAMPADAGlossy White  
glassGlossy Black  
glassCEILING ROSE  
ROSONEBlack  
goffratino





designed by Moreno De Giorgio

**Innate grace.  
Classical and original,  
Grace features a  
natural linen or black  
cotton shade and  
makes the perfect  
addition to different  
settings.**

Grazia innata.  
Classica e ricercata, Grace ha un paralume  
in lino naturale o cotone nero e si inserisce  
alla perfezione in diversi contesti.



PENDANT LAMPS

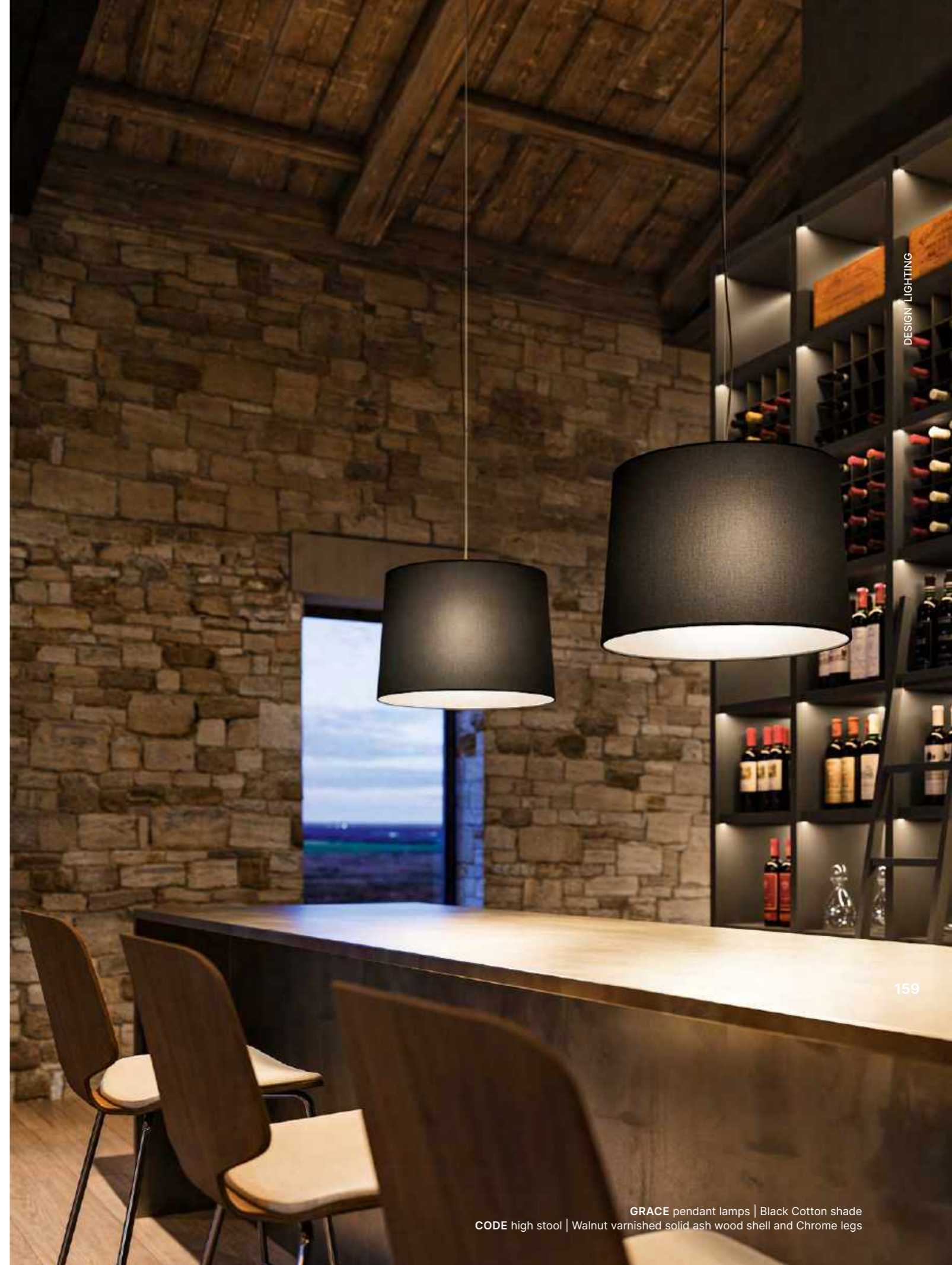





Pendant lamp

GRACE

Pendant lamp with linen or cotton shade.  
Lampada a sospensione con paralume in lino o cotone.

MAX 3XE27 60W  
220-240V  
T/fase

CE IP20

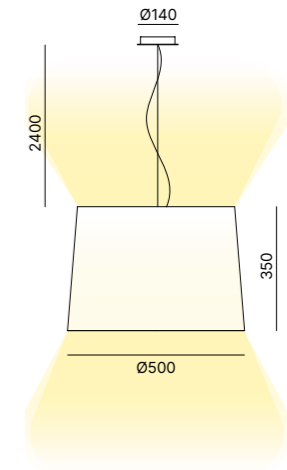

SHADE FINISH OPTIONS  
FINITURE PARALUME



Natural Linen    Black Cotton

CEILING ROSE  
ROSONE



Black goffratino

Grace collection

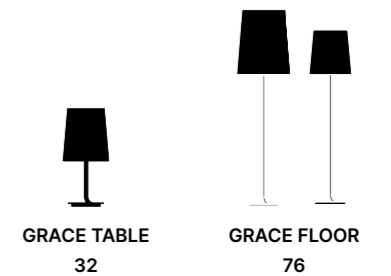

GRACE TABLE  
32

GRACE FLOOR  
76



# HALF MOON

designed by Enrico Franzolini & Vicente García Jimenez

**Eclipse of design.  
Half Moon is simple,  
essential and yet timelessly  
alluring: the colours of the  
shade and the inner part can  
be personalised, bringing  
to life original lamps with a  
modern look.**

**Eclissi di design.**

Half Moon è semplice ed essenziale, ma conserva un fascino senza tempo: i colori del paralume e dell'interno possono essere personalizzati per dare vita a lampade originali dal look moderno.



PENDANT LAMPS





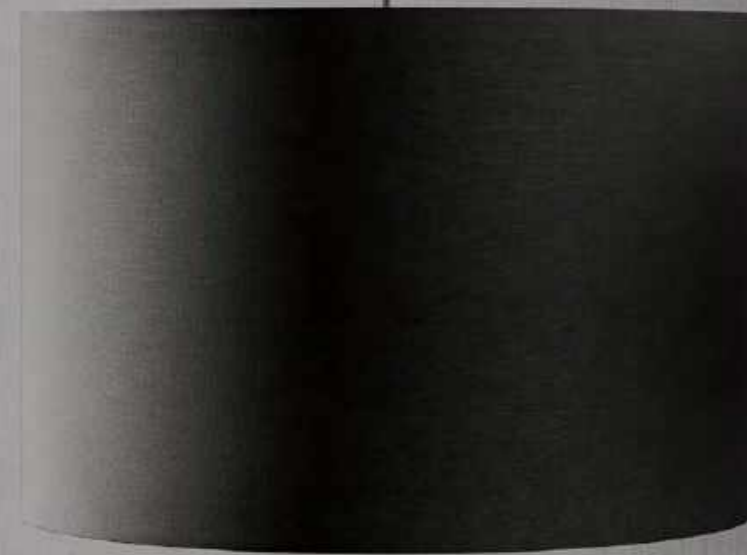

Pendant lamp

HALF MOON

Pendant lamp with linen or cotton shade with white or colored inside.  
 Lampada a sospensione con paralume in lino o cotone, con interno coprente bianco o colorato.

MAX 3XE27 60W  
 220-240V  
 T/fase

CE IP20

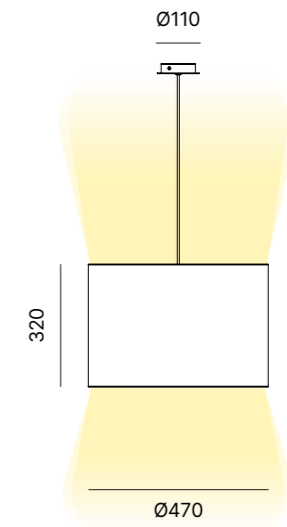

SHADE FINISH OPTIONS  
 FINITURE PARALUME



Black Cotton White inside    Black Cotton Yellow inside    Black Cotton Orange inside    Black Cotton Fuchsia inside    Natural Linen White inside    Natural Linen Yellow inside    Natural Linen Orange inside    Natural Linen Fuchsia inside

FRAME FINISH OPTIONS  
 FINITURE STRUTTURA

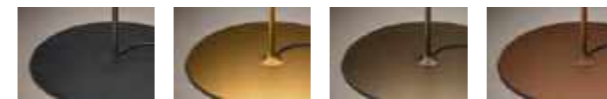

Black Goffratino    Gold    Bronze    Corten

Half Moon collection

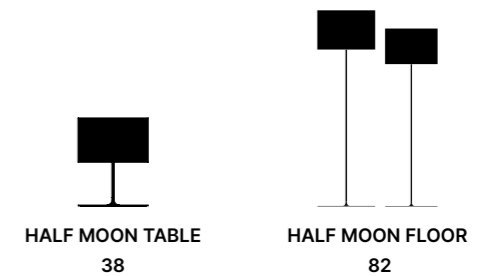



**Enlightened apparition.  
Mirage is the lighting solution  
suitable for elegant and  
chic settings: the shade  
is the same colour as the  
ceiling rose and features a  
chromed external finishing, to  
amplify light and its exquisite  
reflections.**

**Apparizione lucente.  
Mirage è la soluzione di illuminazione adatta a contesti eleganti  
e chic: il paralume, in tinta col rosone, ha la finitura esterna  
cromata per amplificare la luce e i suoi riflessi preziosi.**



PENDANT LAMPS







## Pendant lamp

## MIRAGE

Pendant lamp in powder coated metal, ceiling rose in matching finish.

Lampada a sospensione in metallo verniciato con rosone in tinta.

8,7W LED  
220-240V  
2700K  
CRI80  
T/fase

CE IP20   800lm

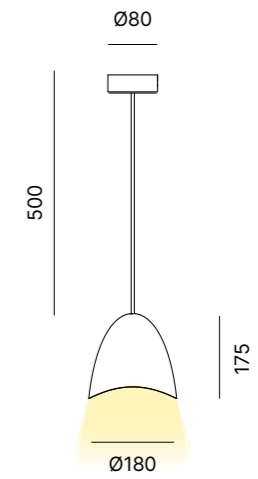
LAMP FINISH OPTIONS  
FINITURE LAMPADA

White

Polished  
ChromePolished  
CopperPolished  
GoldCEILING ROSE  
ROSONE

White

Polished  
ChromePolished  
CopperPolished  
Gold



**Style evolution.**  
**The result of extensive technological research, the fibreglass lampshade of Ola filters light in a unique way through shapes and colours, for material lighting laden with sensations.**

**Stile in divenire.**  
**Frutto di una lunga ricerca tecnologica, il paralume in fibra di vetro di Ola filtra la luce in modo unico attraverso forme e colori, per un'illuminazione materica ricca di sensazioni.**



PENDANT LAMPS







Pendant lamp

OLA

Pendant lamp with fibreglass shade.  
Lampada a sospensione con paralume in fibra di vetro.

MAX 3XE27 60W  
220-240V  
T/fase

CE IP20

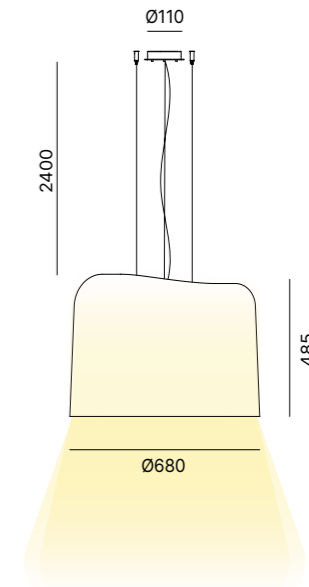

SHADE FINISH OPTIONS  
FINITURE PARALUME



CEILING ROSE  
ROSONE



Black  
goffratino

Ola collection

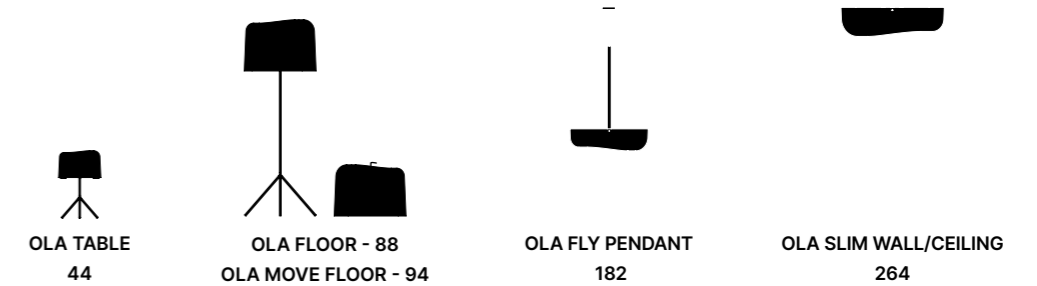



**Dreamy forms.  
Ideal for business and  
hospitality settings, Ola Fly  
reinterprets the tonalities  
of light through the colours  
of its fibreglass shade and  
is available with white, red,  
orange, gold and silver  
finishings.**

Forme sognanti.  
Ideale per ambienti business e hospitality, Ola Fly reinterpreta le  
tonalità della luce attraverso i colori del suo paralume in fibra di  
vetro, nelle finiture bianco, rosso, arancio, oro e argento.



PENDANT LAMPS



OLA FLY pendant lamp | Gold fibreglass shade and Black Goffratino frame



Pendant lamp

Pendant lamp with fibreglass shade.  
Lampada a sospensione con paralume in fibra di vetro.

MAX 3XE27 60W  
220-240V  
T/fase

CE IP20 

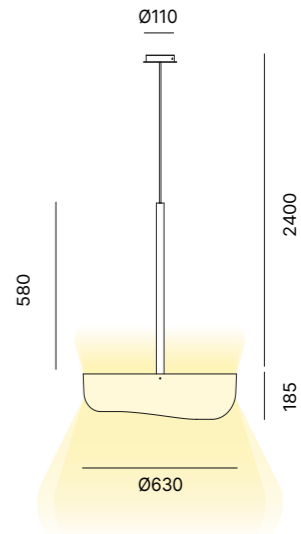

DESIGN LIGHTING



SHADE FINISH OPTIONS  
FINITURE PARALUME

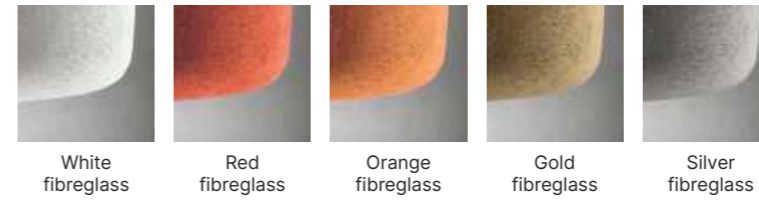

White fibreglass   Red fibreglass   Orange fibreglass   Gold fibreglass   Silver fibreglass

CEILING ROSE  
ROSONE



Black goffratino

Ola collection

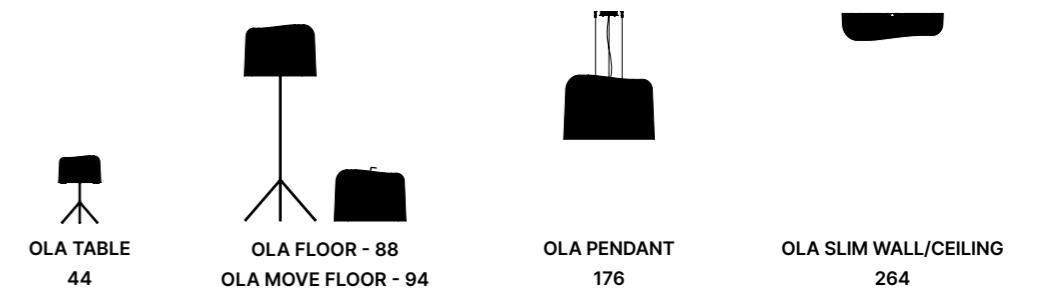

187

186

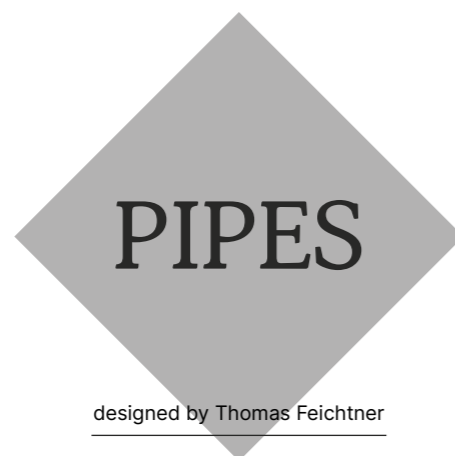

**Gleaming chrome.**  
**Pipes features a tubular structure, consisting of curved and woven aluminium, available in four tonalities: white, bronze, gold and corten. It reigns supreme in dining rooms, reception areas and convivial settings.**

**Chioma brillante.**

Pipes ha una struttura tubolare, formata da alluminio curvato e intrecciato, disponibile in quattro tonalità: bianco, bronzo, oro e corten. È la protagonista di sale da pranzo, aree reception e luoghi conviviali.



PENDANT LAMPS







## Pendant lamp

## PIPES

Pendant lamp made by powder coated aluminium pipes.  
Lampada a sospensione composta da tubi in alluminio verniciati.

16X1W LED  
2700K  
CRI80  
DALI/Push dimm

CE IP20   1400lm

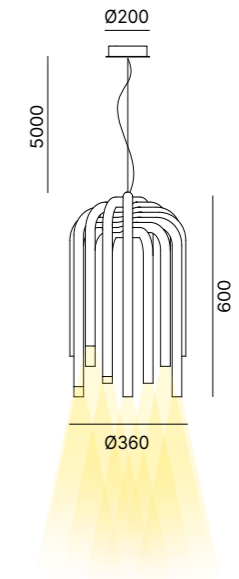

### SHADE FINISH OPTIONS FINITURE PARALUME



Matt White

Gold

Bronze

Corten

### CEILING ROSE ROSONE



Matt White



**Suspended galaxy.  
Light propagates in Planet  
from the curved aluminium  
circle, available in 3 diameter  
sizes and different finishings,  
resulting in the perfect  
lighting for boardroom and  
meeting interiors.**

Galassia sospesa.  
La luce di Planet si propaga dal cerchio in alluminio calandrato,  
disponibile in 3 misure di diametro e in diverse finiture:  
l'illuminazione perfetta per spazi di rappresentanza e di incontro.



PENDANT LAMPS







The LED lighting, which is both direct and indirect, resides in the circular profile, and it is equipped with an intensity-adjustable diffuser.

L'illuminazione a led, diretta e indiretta, risiede nel profilo circolare, il quale è dotato di diffusore regolabile in intensità.





Pendant lamp

PLANET

Pendant lamp in powder coated aluminium.  
Lampada a sospensione in alluminio verniciato.

Planet 70	Planet 90	Planet 110
2700K	2700K	2700K
CRI90	CRI90	CRI90
ON-OFF   All in one	ON-OFF   All in one	ON-OFF   All in one
Down light	Down light	Down light
24W LED	42W LED	50W LED
4480 lm	5600 lm	6720lm
Up/Down light	Up/Down light	Up/Down light
48W LED	84W LED	100W LED
8960 lm	11200lm	13440lm

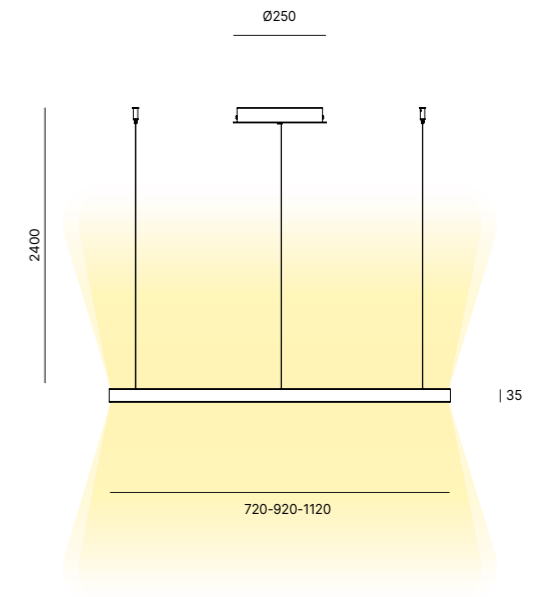

CE IP20 LED 24V MacAdam Step 3

SHADE FINISH OPTIONS  
FINITURE PARALUME



CEILING ROSE  
ROSONE



Matt White





designed by Enrico Franzolini

**Cut of light.**  
**Slice features a clean-cut and decisive aluminium profile: it diffuses punctual light and can be articulated in compositions consisting of several items or a single lamp, for lighting in living, hospitality and business settings.**

Taglio di luce.

Slice ha un profilo in alluminio netto e deciso: diffonde una luce puntuale e si può articolare in composizioni a più pezzi o con lampada singola, per illuminare spazi living, hospitality e business.



PENDANT LAMPS

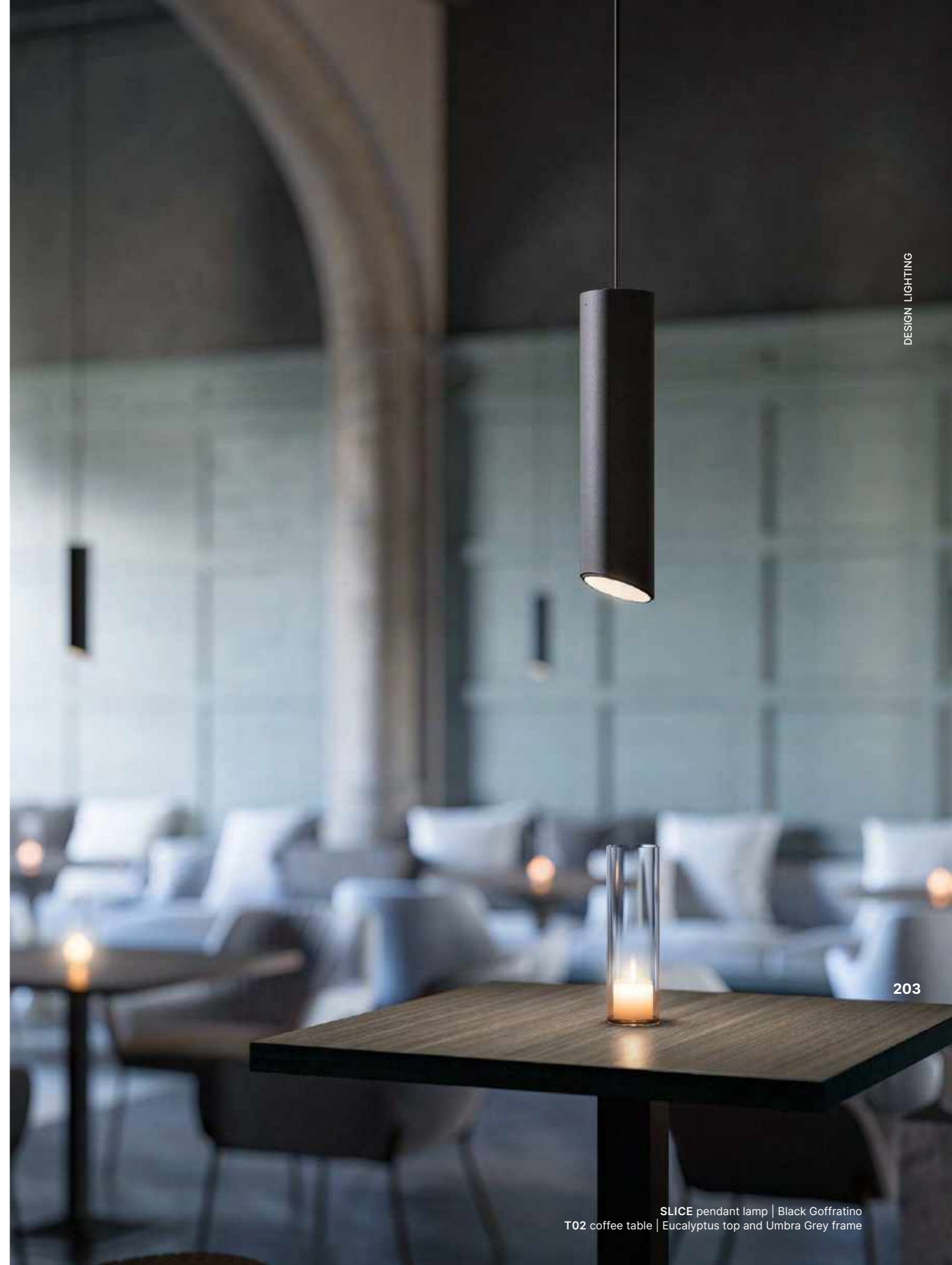



Pendant lamp

SLICE

Pendant lamp in powder coated aluminium.  
Lampada a sospensione in alluminio verniciato.

4W LED  
220-240V  
2700K  
CRI90  
T/fase | DALI/Push dimm

CE IP20 LED 45-60° 500lm MacAdam Step 3

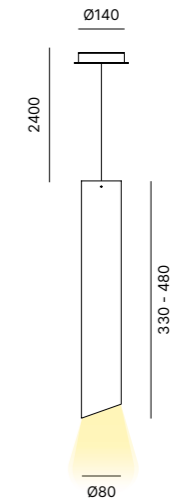

LAMP FINISH OPTIONS  
FINITURE LAMPADA



Matt White Black Goffratino Gold Bronze Corten

CEILING ROSE  
ROSONE



Black Goffratino

REFLECTOR FINISH OPTIONS  
FINITURE RIFLETTORE



Matt White Black Goffratino Gold Bronze Corten

Slice collection

SLICE WALL/CEILING  
276



# STARLIGHT

designed by Serena Papait

**Slender elegance.  
Starlight is a veritable  
geometric sculpture with  
soft and indirect led lighting.  
It creates plays of shadows  
and lights and is suitable  
for enhancing a suffused  
ambience in refined settings.**

**Esile eleganza.  
Starlight è una vera e propria scultura geometrica con  
illuminazione a led soft e indiretta. Crea giochi di ombre e riflessi,  
adatti a suggerire atmosfere soffuse per ambienti ricercati.**



PENDANT LAMPS



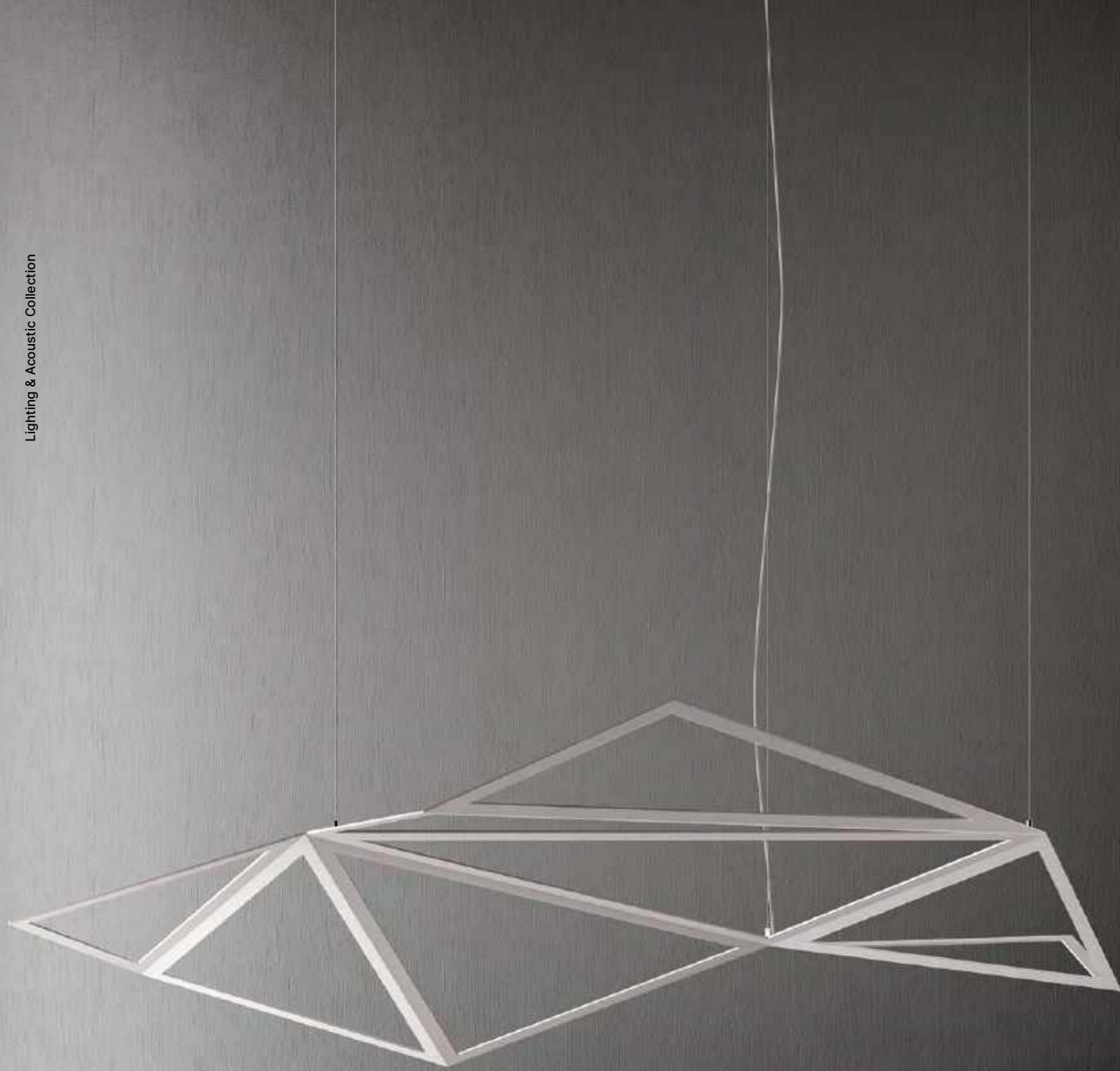

Pendant lamp

STARLIGHT

Pendant lamp in powder coated aluminium, up light.  
Lampada a sospensione in alluminio verniciato, luce indiretta.

Starlight	Starlight Giant
39W LED	50W LED
2700 lm	5400 lm
2700K	2700K
CRI90	CRI90
DALI/Push dimm	DALI/Push dimm

CE IP20

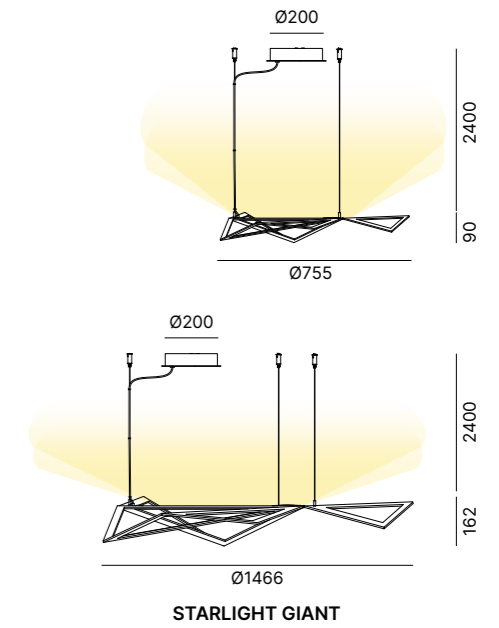

LAMP FINISH OPTIONS  
FINITURE LAMPADA

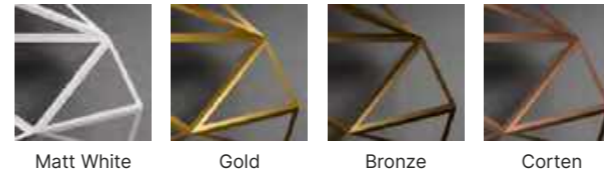

CEILING ROSE  
ROSONE



Matt White

Starlight collection

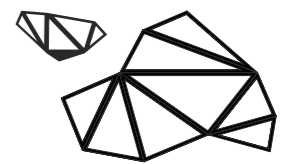

STARLIGHT WALL  
282



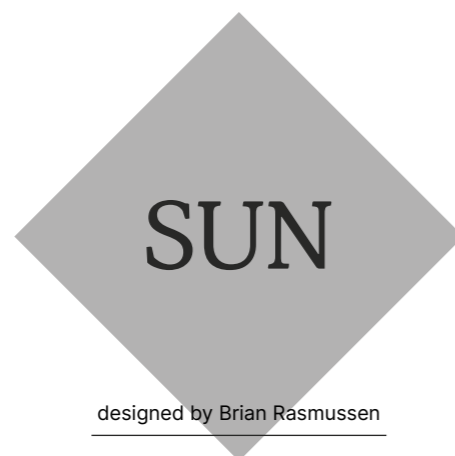

designed by Brian Rasmussen

**Solar creativity.  
Sun multiplies, fragments  
and adds dynamism to light  
through the eccentric woven  
fabric shade, customisable in  
three tonalities. The suspended  
version is available in two  
sizes, adding character to  
contemporary settings.**

Creatività solare.

Sun moltiplica, frammenta e rende dinamica la luce attraverso l'eccentrico paralume in tessuto lavorato, personalizzabile in tre tonalità. La versione a sospensione è disponibile in due dimensioni, per dare carattere ad ambienti contemporanei.



PENDANT LAMPS





Pendant lamp

SUN

Pendant lamp with fabric shade.  
Lampada a sospensione con paralume in tessuto.

Sun 50	Sun 75
MAX 1XE27 100W	MAX 3XE27 60W
220-240V	220-240V
T/fase	T/fase

CE IP20

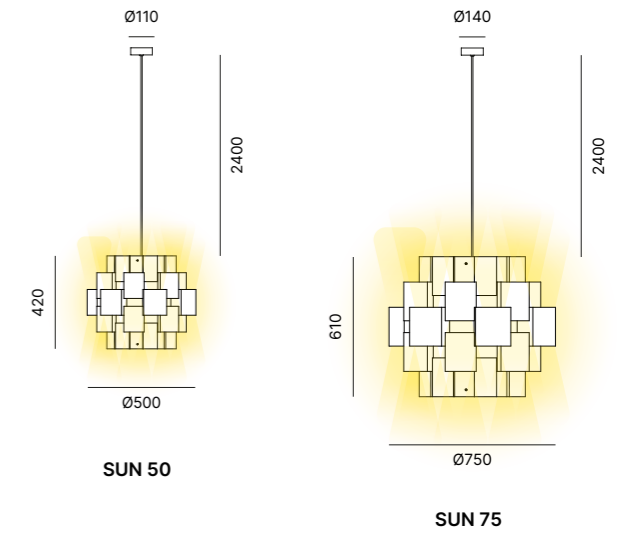

SHADE FINISH OPTIONS  
FINITURE PARALUME

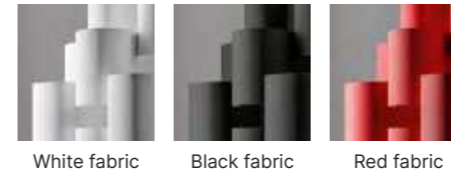

CEILING ROSE  
ROSONE



Matt White

Sun collection

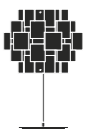

SUN TABLE  
50





**Diffused allure.  
Sveva is the queen in any  
setting, delivering pleasant  
and diffused light in business  
and hospitality interiors  
while seamlessly matching  
different styles thanks to  
customisation options for its  
finishings.**

**Charme diffuso.  
Sveva è la regina di ogni spazio: getta una luce garbata e diffusa  
su ambienti business e hospitality e si intona a diversi contesti  
grazie alla possibilità di personalizzare le finiture.**



PENDANT LAMPS





## Pendant lamp

SVEVA

Pendant lamp in powder coated aluminium.

Matt methacrylate diffuser.

Lampada a sospensione in alluminio verniciato.



Diffusore in metacrilato opalino.

35,2W LED

3000K

CRI90

ON-OFF | All in one

CE IP20   24V 4400lm  MacAdam Step 3

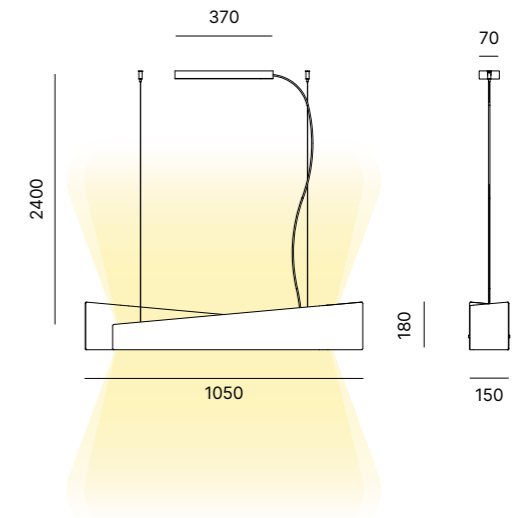

LAMP FINISH OPTIONS  
FINITURE LAMPADA

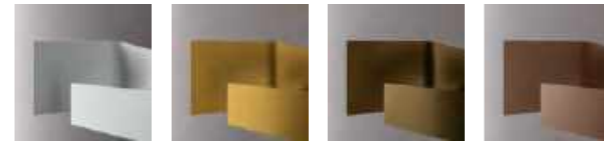

Matt White

Gold

Bronze

Corten

DIFFUSER  
DIFFUSORE



PMMA



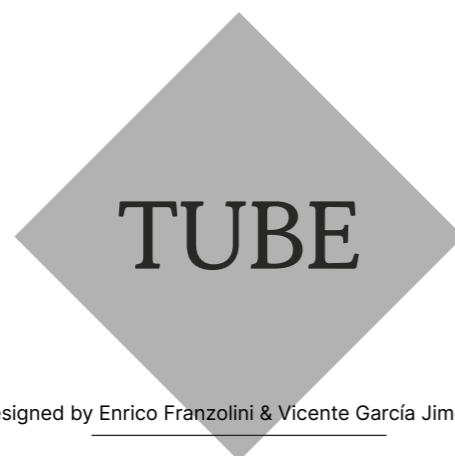

designed by Enrico Franzolini & Vicente García Jimenez

**Winning simplicity.**  
**Tube is an equation that  
 resolves all project design  
 and aesthetic requirements:  
 80 mm diameter, 2 available  
 lengths and a choice of  
 5 finishings and infinite  
 modulation options, with one  
 or more lamps.**

Semplicità vincente.

Tube è un'equazione che risolve ogni esigenza progettuale ed estetica: 80 mm di diametro, 2 lunghezze disponibili, 5 finiture tra cui scegliere e infinite possibilità di modulazione, con lampada singola o più lampade.



PENDANT LAMPS





Pendant lamp

TUBE

Pendant lamp in powder coated aluminium.  
Lampada a sospensione in alluminio verniciato.

4W LED  
220-240V  
2700K  
CRI90  
T/fase | DALI/Push dimm

CE IP20 LED 45-60° 500lm MacAdam Step 3

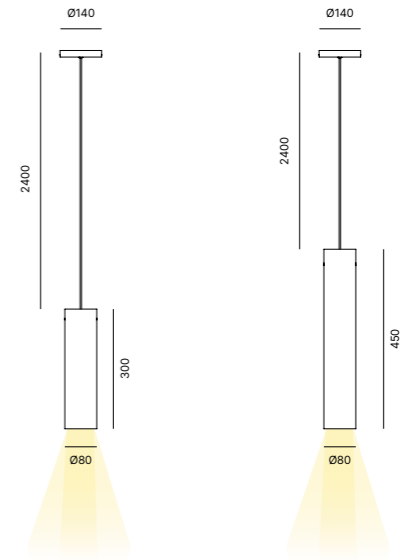

SHADE FINISH OPTIONS  
FINITURE PARALUME



CEILING ROSE  
ROSONE

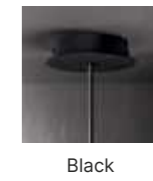

REFLECTOR FINISH OPTIONS  
FINITURE RIFLETTORE



Tube collection



TUBE MICRO PENDANT  
232

TUBE WALL/CEILING  
288



# TUBE MICRO

designed by Quadrifoglio Group

**Slender soul.**  
Tube Micro illuminates residential and professional settings with versatile compositions: cascades, sprinkles, duets and monologues of light inspired by lightness and elegance. The punctual light showcases any furnishing detail.

Anima sottile.

Tube Micro illumina ambienti residenziali e professionali con composizioni versatili: cascate, piogge, duetti e monologhi di luce all'insegna della leggerezza e dell'eleganza. La luce puntuale rende protagonisti i dettagli di ogni arredo.



TABLE LAMPS

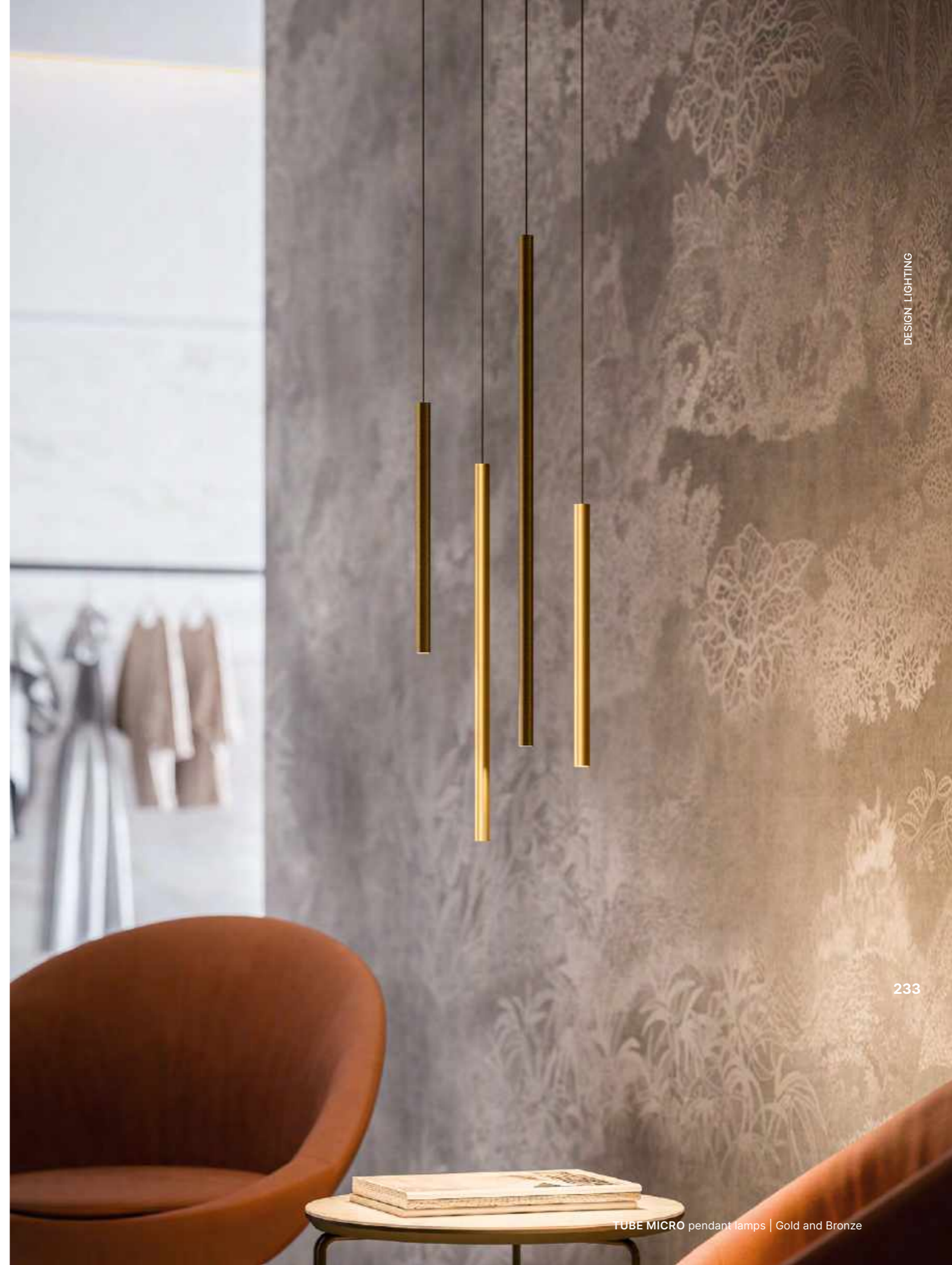



### Pendant lamp

## TUBE MICRO

Pendant lamp in powder coated aluminium.  
 Lampada a sospensione in alluminio verniciato.

1,5W LED  
 2700K  
 CRI90  
 ON-OFF

CE IP20 150lm



#### SHADE FINISH OPTIONS FINITURE PARALUME



Matt White    Black Goffratino    Gold    Bronze    Corten

### Tube collection

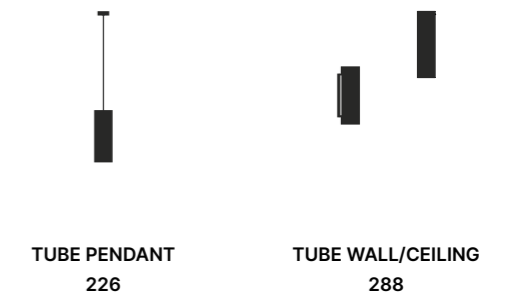

TUBE PENDANT  
226

TUBE WALL/CEILING  
288



# Wall/Ceiling Lamps

Decorative Lighting



## Wall/Ceiling lamps



ALALUNGA  
ALALUNGA WALL - 240



CD LED  
CD LED WALL - 246



DRINK  
DRINK CEILING - 252



ESCAPE  
ESCAPE WALL - 258



OLA SLIM  
OLA SLIM WALL/CEILING - 264



SHADOW  
SHADOW WALL - 270



SLICE  
SLICE CEILING - 276

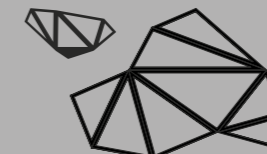

STARLIGHT  
STARLIGHT WALL - 282

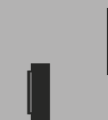

TUBE  
TUBE WALL/CEILING - 288



TUPLA  
TUPLA WALL - 296



TURN ME!  
TURN ME! WALL - 302



# ALALUNGA

designed by Enrico Franzolini

**The beat of a wing.  
Alalunga is a wall-hung painted metal appliqué available in two sizes and four deluxe finishings. Its elegant and luminous presence enhances contemporary and exclusive settings with delicate lighting.**

#### Battito d'ali.

Alalunga è un'applique da parete in metallo verniciato, disponibile in due dimensioni e quattro finiture deluxe. La sua presenza, leggiadra e luminosa, valorizza ambienti contemporanei ed esclusivi con un'illuminazione leggera.



WALL/CEILING LAMPS









Wall lamp

ALALUNGA

Wall lamp in powder coated metal.  
Lampada a parete in metallo verniciato.

Alalunga Mini	Alalunga
9W LED	12W LED
220-240V	110-240V
2700K	2700K
CRI90	CRI90
T/fase	T/fase   DALI/Push dimm

CE IP20  

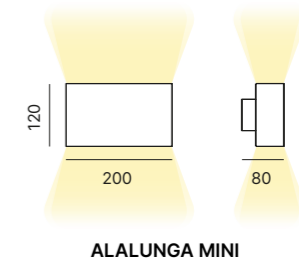

ALALUNGA MINI

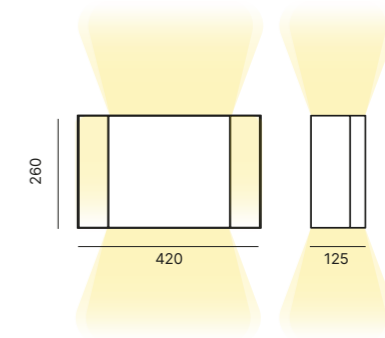

ALALUNGA

SHADE FINISH OPTIONS  
FINITURE PARALUME



Matt White

Gold

Bronze

Corten





**Intense constellations.  
Refined and shaded wall  
lighting: CD Led in the appliqué  
version is available in numerous  
colours and three shapes,  
modulable in single or multiple  
compositions that are always  
new and surprising.**

**Costellazioni intense.  
Un'illuminazione a parete raffinata e sfumata: CD Led in versione applique  
è disponibile in numerosi colori e in tre forme, modulabili in composizioni,  
singole o plurime, sempre nuove e sorprendenti.**





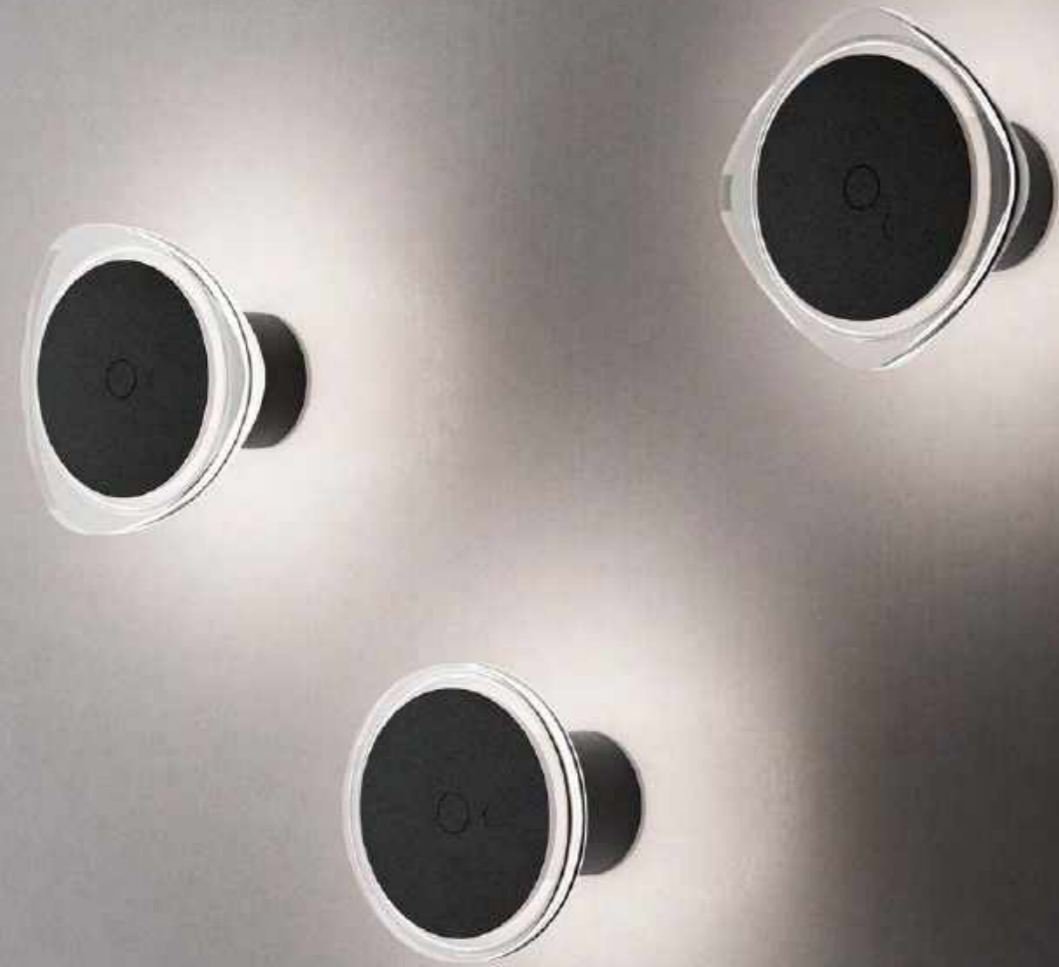

Wall lamp

CD LED

Polycarbonate lamp diffuser with transparent or colored PMMA ring, powder coated metal frame.  
 Diffusore in policarbonato con anello in PMMA trasparente o colorato, struttura in metallo verniciato.

9,5W LED  
 220-240V  
 2700K  
 CRI90  
 ON-OFF | T/fase

CE IP20 LED 24V 1020lm MacAdam Step 3

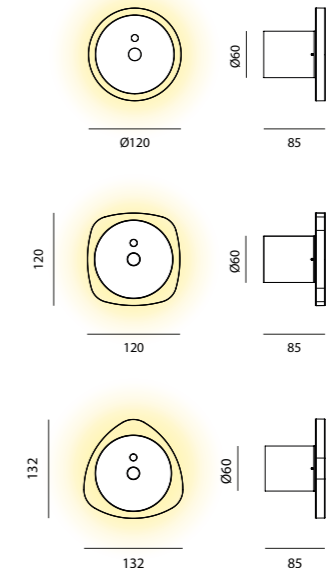

FINISH OPTIONS  
 FINITURE



FRAME FINISH OPTIONS  
 FINITURE STRUTTURA



Black Goffratino

CD Led collection

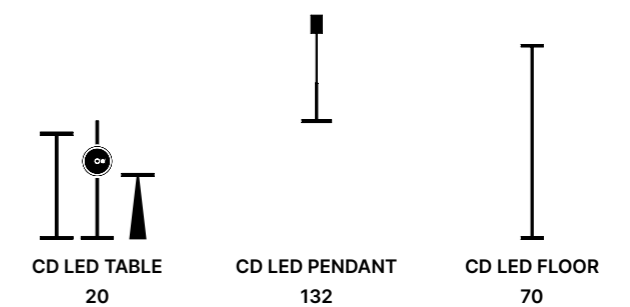



designed by Enrico Franzolini & Vicente García Jimenez

**Convivial lighting.  
Drink is the perfect pendant  
lamp for restaurants, hotels,  
wineries, clubs and other  
shared spaces. The aluminium  
structure is orientable and  
adjustable according to  
needs, for lighting tables and  
seating.**

**illuminazione conviviale.**

Drink è la lampada a sospensione perfetta per ristoranti, hotel, enoteche, club e altri spazi di condivisione. La struttura in alluminio è orientabile e regolabile a seconda delle esigenze, per illuminare tavoli e sedute.



WALL/CEILING LAMPS







### Ceiling lamp

# DRINK

Ceiling lamp in powder coated aluminium.  
Lampada a soffitto in alluminio verniciato.

4W LED  
220-240V  
2700K  
CRI90  
T/fase | DALI/Push dimm

CE IP20 LED 45-60° 500lm MacAdam Step 3

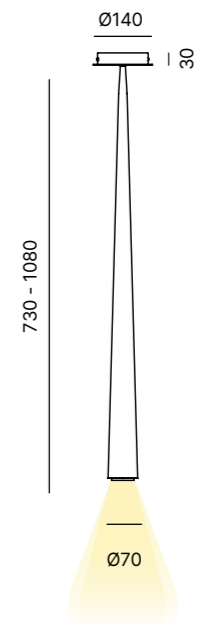

#### LAMP AND CEILING ROSE FINISH OPTIONS FINITURE LAMPADA E ROSONE



#### REFLECTOR FINISH OPTIONS FINITURE RIFLETTORE



### Drink collection



DRINK PENDANT  
140



**A play of planes.  
Escape is available in different  
colours and three sizes, from  
big to small. Its light glides from  
one level to another, creating a  
dynamic and vibrant effect, ideal  
for lighting in residential and  
hospitality settings.**

**Gioco di piani.**  
Escape è disponibile in diversi colori e in tre dimensioni, dalla più  
compatta alla più estesa: la sua luce scivola da un livello all'altro  
creando un effetto dinamico e vibrante, ideale per illuminare  
ambienti residenziali e spazi ricettivi.





## Wall lamp

## ESCAPE

Wall lamp in powder coated aluminium.

Matt methacrylate diffuser.

Lampada a parete in alluminio verniciato. Diffusore in metacrilato opalino.

Escape Cube	Escape 50	Escape 80
8,7W LED	11,3W LED	22,6W LED
800 lm	1440 lm	2880 lm
220-240V	220-240V	220-240V
2700K	2700K	2700K
CRI80	CRI80	CRI80
T/fase	On/Off   DALI/ Push dimm	On/Off   DALI/ Push dimm

CE IP20   MacAdam Step 3

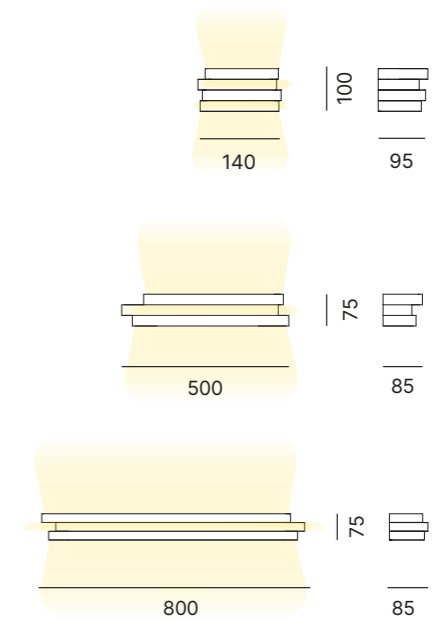

LAMP FINISH OPTIONS  
FINITURE LAMPADA



Matt White

Gold

Bronze

Corten

## Escape collection

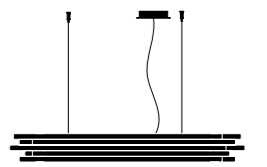

ESCAPE PENDANT  
146

# OLA SLIM

designed by Enrico Franzolini

**Lunar Ambience.  
Light becomes tactile  
perception thanks to the  
fibreglass shade filter of  
Ola Slim, the wall lamp  
that evokes suggestions  
from other worlds, in any  
interior.**

**Atmosfere lunari.  
La luce si fa percezione tattile grazie al filtro del paralume in  
fibra di vetro di Ola Slim, la lampada a parete capace di evocare  
suggerimenti di altri mondi in ogni ambiente.**

  
WALL/CEILING LAMPS







Wall/Ceiling lamp

OLA SLIM

Wall/Ceiling lamp with fibreglass shade.  
Lampada a parete/soffitto con paralume in fibra di vetro.

MAX 3XE27 60W  
220-240V  
T/fase

CE IP20 ⚡

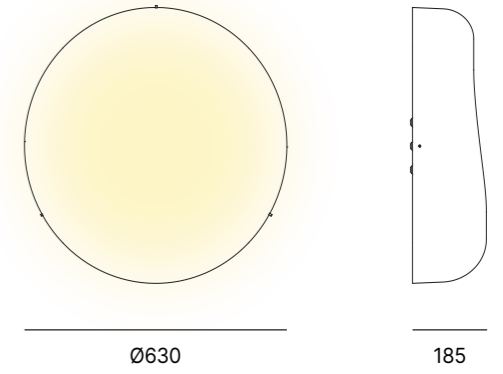

SHADE FINISH OPTIONS  
FINITURE PARALUME

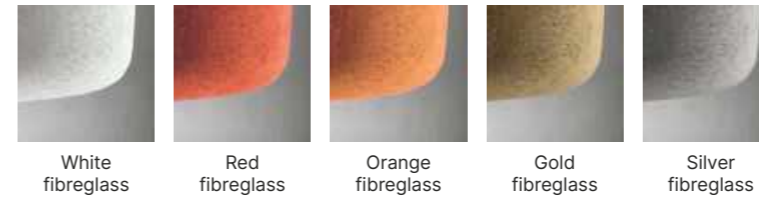

White fibreglass   Red fibreglass   Orange fibreglass   Gold fibreglass   Silver fibreglass

Ola collection

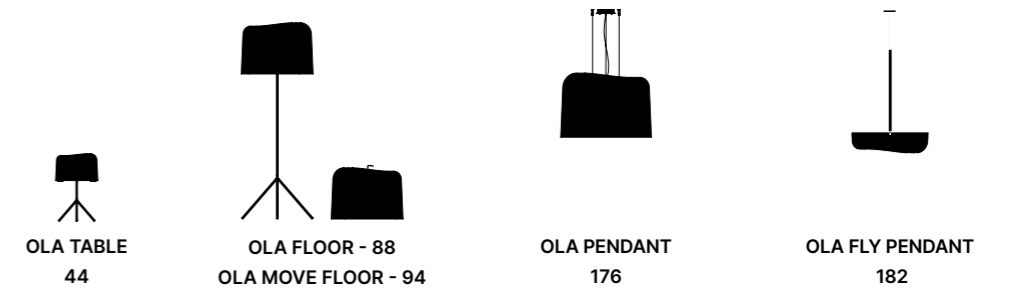

OLA TABLE  
44

OLA FLOOR - 88  
OLA MOVE FLOOR - 94

OLA PENDANT  
176

OLA FLY PENDANT  
182



**Shadow inclinations.  
Shadow shields and  
unleashes light according to  
need, thanks to the orientable  
diffuser and dimmer device  
for adjusting intensity. Light  
and shade coexist in an ever-  
active balance.**

**Inclinazioni d'ombra.  
Shadow schermo e libera la luce a seconda delle esigenze  
grazie al diffusore orientabile e al dispositivo dimmer per  
regolare l'intensità. Nel suo design luce e ombra convivono  
in un equilibrio sempre attivo.**

  
WALL/CEILING LAMPS







## Wall lamp

## SHADOW

Wall lamp in powder coated metal.  
Lampada a parete in metallo verniciato.

Shadow 33	Shadow 63
16W LED	24W LED
1600 lm	2400 lm
220-240V	220-240V
2700K	2700K
CRI80	CRI80
T/fase	T/fase

CE IP20  

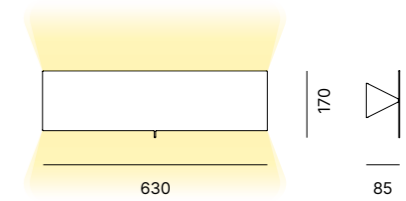
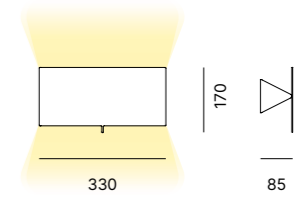

SHADE FINISH OPTIONS  
FINITURE PARALUME

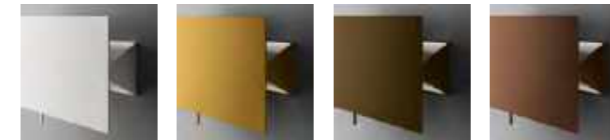

Matt White

Gold

Bronze

Corten



designed by Enrico Franzolini & Vicente García Jimenez

**Decisive character.  
Cylindrical shape and direct  
light: Slice is a lamp with  
a decisive personality and  
is fitted directly onto the  
ceiling without a rose, ideal  
for modern settings with an  
minimalistic style.**

**Carattere deciso.**

**Forma cilindrica e luce diretta: Slice è una lampada dalla personalità risoluta, si applica direttamente al soffitto senza l'ausilio di un rosone ed è ideale per contesti dallo stile moderno e minimal.**

276



WALL/CEILING LAMPS



277





278

SLICE ceiling lamps | Black Goffratino lamp with Gold reflector  
 LIBRERIA bookshelves | Umbra Grey lacquer  
 CLEOPAS armchair and ottoman | E03/463 fabric and Umbra Grey base

The diagonal cut of light in Slice provides lighting that is punctual and pleasant in interiors. The lamp is available in white, embossed black, gold, bronze and corten, to match different styles.

Il taglio diagonale della luce di Slice permette di illuminare gli ambienti in modo puntuale e piacevole. La lampada è disponibile in bianco, nero goffratino, oro, bronzo e corten, per intonarsi a stili diversi.



279





Ceiling lamp

SLICE

Ceiling lamp in powder coated aluminium.  
Lampada a soffitto in alluminio verniciato.

4W LED  
220-240V  
2700K  
CRI90  
T/fase | DALI/Push dimm

CE IP20 LED 45-60° 500lm MacAdam Step 3

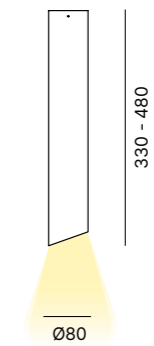

LAMP FINISH OPTIONS  
FINITURE LAMPADA



REFLECTOR FINISH OPTIONS  
FINITURE RIFLETTORE



Slice collection



SLICE PENDANT  
202



# STARLIGHT

designed by Serena Papait

**Configurable geometries. Starlight is available in two sizes and numerous compositions: its changeable shape illuminates residential and professional settings with radiant reflections and plays of indirect light, for a suffused and soft effect.**

Geometrie componibili.

Starlight è disponibile in due dimensioni e numerose composizioni: la sua forma mutevole illumina ambienti residenziali e professionali con riflessi luminosi e giochi di luce indiretti, per un effetto di soffusa morbidezza.



WALL/CEILING LAMPS







Wall lamp

STARLIGHT

Wall lamp in powder coated aluminium.  
Lampada a parete in alluminio verniciato.



**Starlight**

19W LED  
2000 lm  
110-240V  
2700K  
CRI90  
ON-OFF

CE IP20  

**Starlight Giant**

50W LED  
5400 lm  
2700K  
CRI90  
DALI/Push dimm

CE IP20  

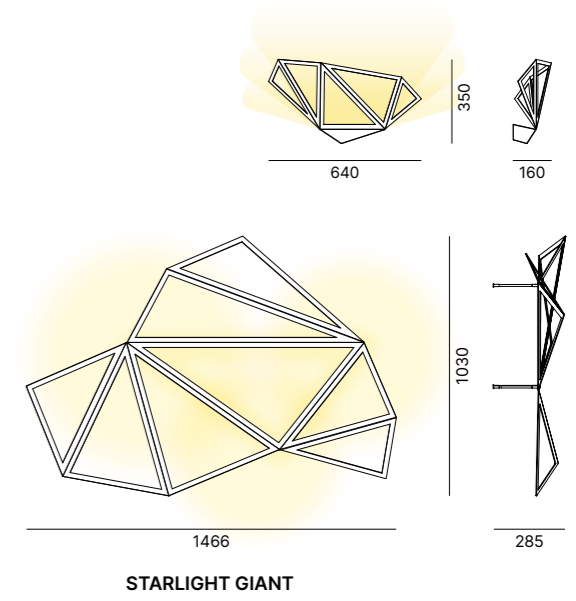

LAMP FINISH OPTIONS  
FINITURE LAMPADA

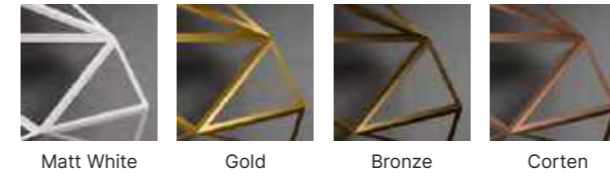

Matt White

Gold

Bronze

Corten

Starlight collection



STARLIGHT PENDANT  
208





designed by Enrico Franzolini & Vicente García Jimenez

**Enlightened synthesis.  
Available in the ceiling or  
wall hung version, Tube is  
the lighting solution suitable  
for different project design  
and aesthetic requirements:  
two sizes, five finishings  
and a multitude of  
installation options.**

Sintesi illuminata.

Disponibile nella versione a soffitto o a parete, Tube è la soluzione di illuminazione adatta per diverse esigenze progettuali ed estetiche: due misure, cinque finiture e molteplici possibilità di installazione.



WALL/CEILING LAMPS





TUBE ceiling lamps | Black Goffratino lamp with Gold reflector  
 CITY LOUNGE armchair | D05/413 fabric and Oak varnished solid ash wood legs  
 MELBOURNE side table | Fokos Terra porcelain stoneware top and Oak varnished solid ash wood legs

**Its light is punctual, a lamp that is simple in appearance but makes an impact in any space, whether residential or business.**

La sua luce è puntuale, una lampada semplice all'apparenza ma d'impatto in qualsiasi spazio, sia residenziale che business.







Ceiling lamp

TUBE

Ceiling lamp in powder coated aluminium.  
Lampada a soffitto in alluminio verniciato.

4W LED  
220-240V  
2700K  
CRI90  
T/fase | DALI/Push dimm

CE IP20 LED 45-60° 500lm MacAdam Step 3

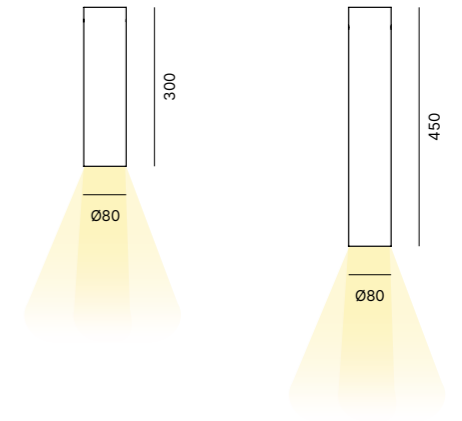

SHADE FINISH OPTIONS  
FINITURE PARALUME

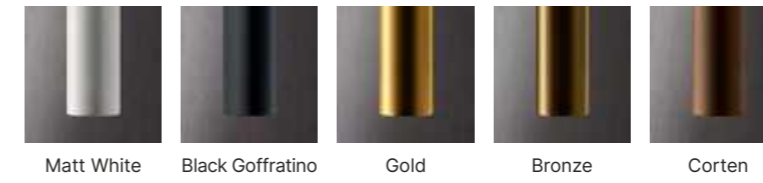

REFLECTOR FINISH OPTIONS  
FINITURE RIFLETTORE



Tube collection

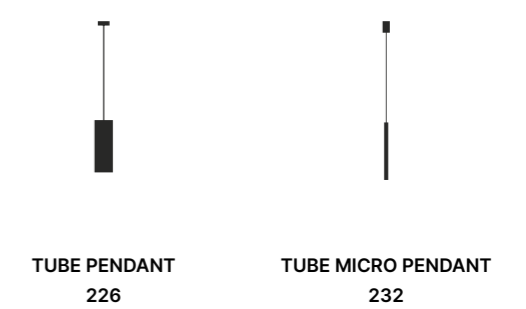



Wall lamp

TUBE

Wall lamp in powder coated aluminium.  
Lampada a parete in alluminio verniciato.

8W LED  
220-240V  
2700K  
CRI90  
T/fase | DALI/Push dimm

CE IP20 LED 45-60° 1000lm MacAdam Step 3

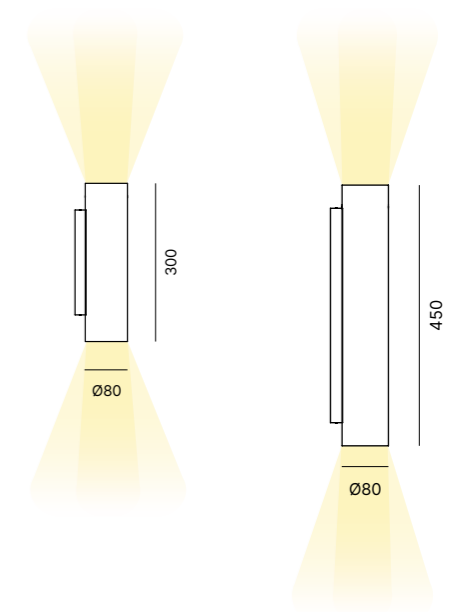

SHADE FINISH OPTIONS  
FINITURE PARALUME

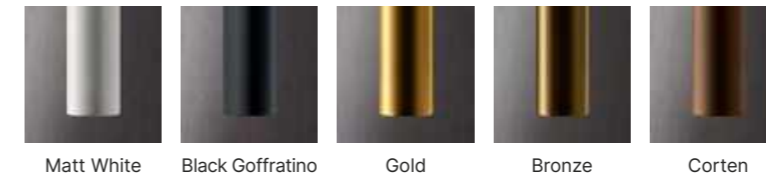

REFLECTOR FINISH OPTIONS  
FINITURE RIFLETTORE



Tube collection

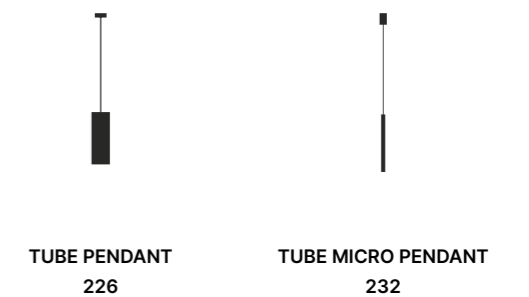



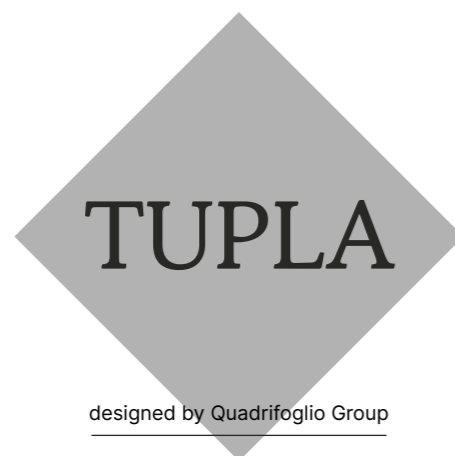

**Pure light.**  
**Tupla is the wall lamp for residential and hospitality settings: its simple and succinct shape, combined with the warm and adjustable light, creates a unique ambience every time.**

**Pura luce.**  
**Tupla è la lampada a parete ideale per ambienti residenziali e di hospitality: la forma semplice e sintetica, unita alla luce calda e regolabile, crea un'atmosfera ogni volta unica.**

  
WALL/CEILING LAMPS

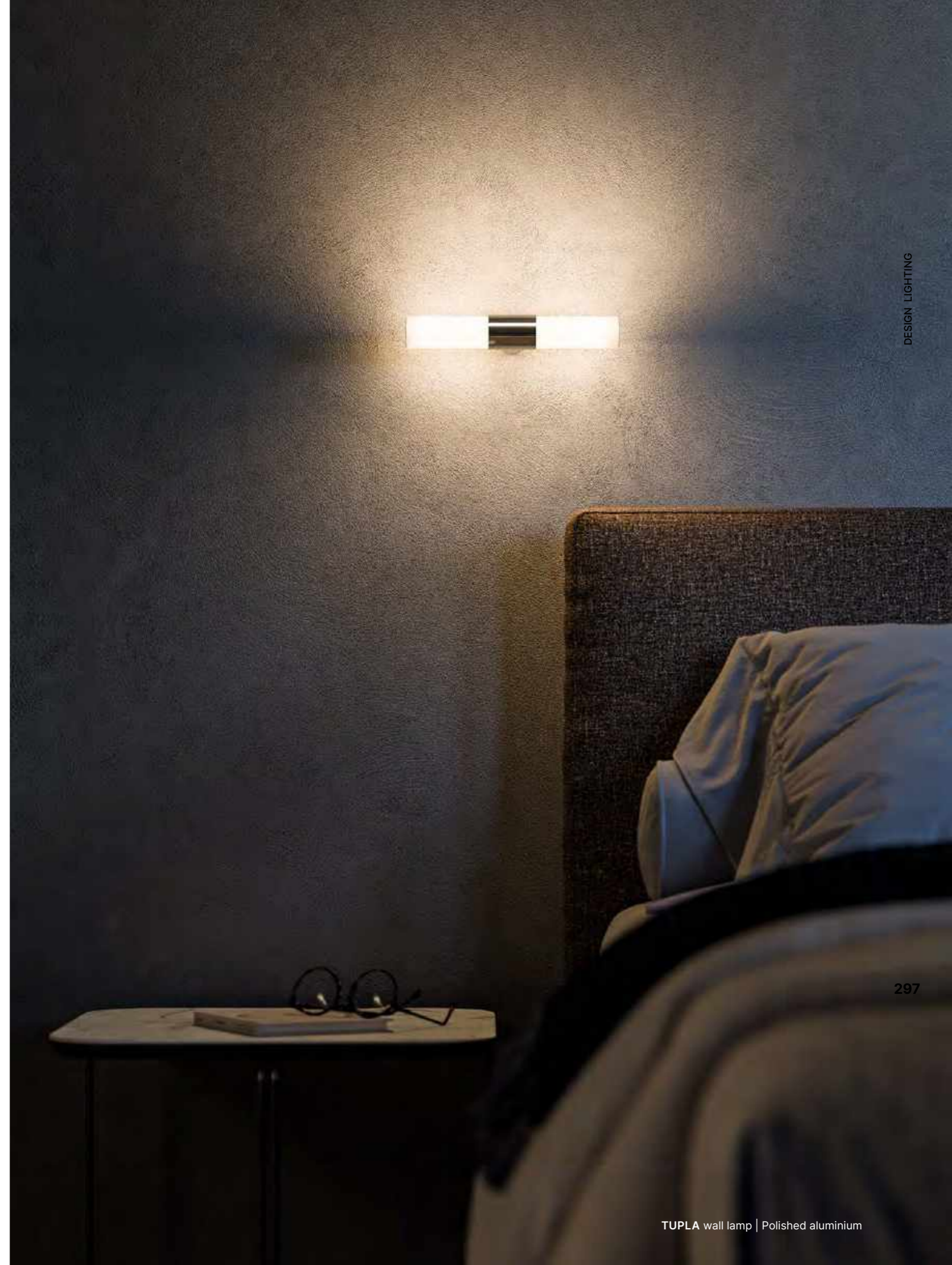

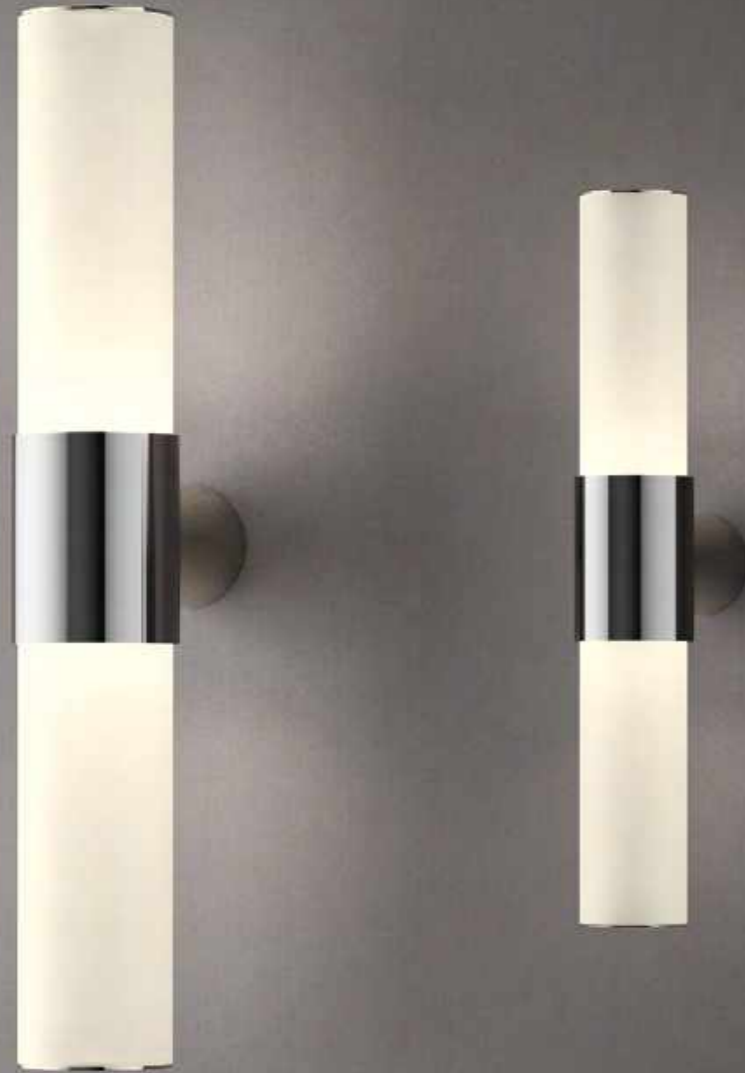

## Wall lamp

## TUPLA

Wall lamp with polished aluminium frame and matt methacrylate shade.

Lampada a parete con struttura in alluminio lucidato e paralume in metacrilato opalino.



**Tupla 28**

2X4,3W LED  
800 lm  
220-240V  
2700K  
CRI80  
T/fase

**Tupla 40**

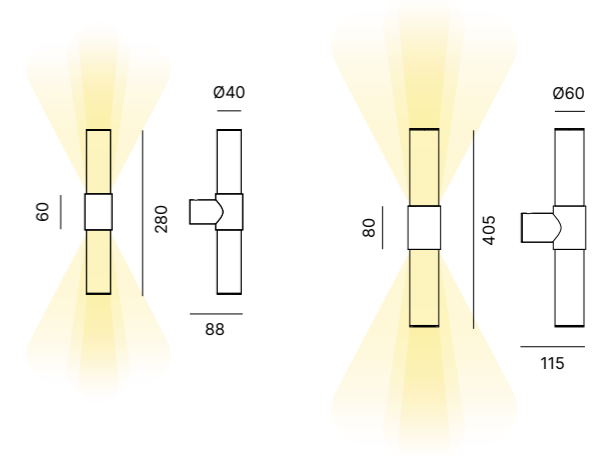
2X8,7W LED  
1600 lm  
220-240V  
2700K  
CRI80  
T/fase



CE IP20  

SHADE FINISH OPTIONS  
FINITURE PARALUME

Polished  
aluminium



# TURN ME!

designed by Marta Laudani & Marco Romanelli

**Changeable personality.  
Turn me! is the wall lamp  
that innovates the concept  
of lighting: thanks to its  
rotating structure, light  
can be directed any way,  
according to needs.**

**Personalità mutevole.  
Turn me! è la lampada a parete che innova  
il concetto di illuminazione: grazie alla sua  
struttura rotante, si può direzionare la luce a  
piacimento a seconda delle necessità.**

  
WALL/CEILING LAMPS



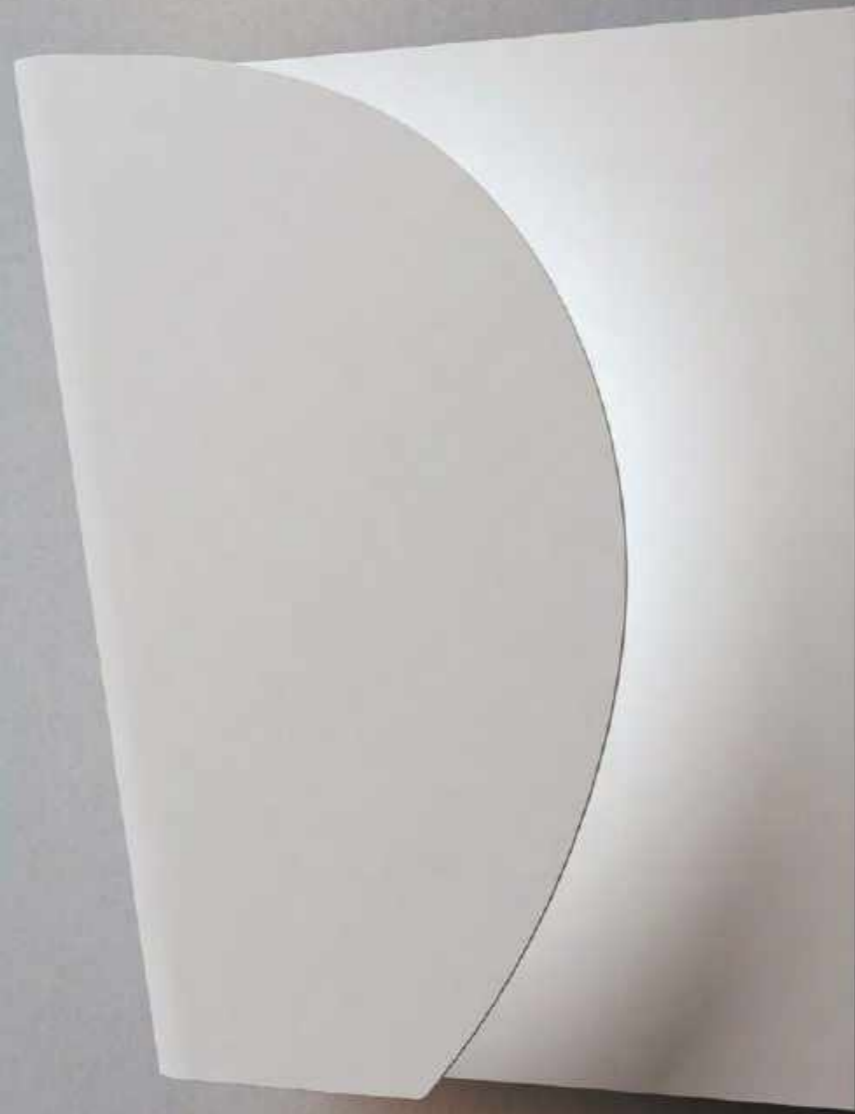

### Wall lamp

### TURN ME!

Wall lamp in powder coated aluminium.  
Lampada a parete in alluminio verniciato.

8W LED  
220-240V  
2700K  
CRI80  
T/fase

CE IP20   1300lm

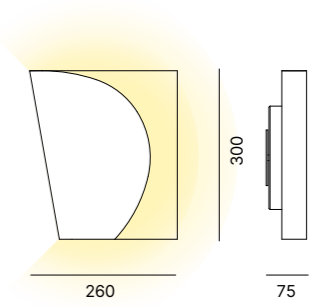

#### LAMP FINISH OPTIONS FINITURE LAMPADA

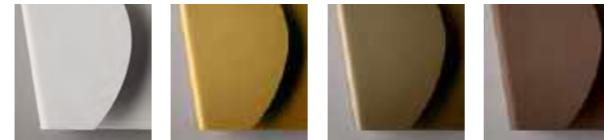

Matt White    Gold    Bronze    Corten

#### DETAILS DETTAGLI





## Architectural Lighting

**Minimalistic ambience. Comfort, authoritativeness, refinement, completeness: the sensations given off by any setting are all a matter of light. Architectural systems are modular and configurable, for complete freedom of design in living and professional settings.**

Atmosfere minimal.  
Accoglienza, autorevolezza, raffinatezza, completezza:  
le sensazioni che restituisce uno spazio sono una  
questione di luce. I sistemi architettonici sono modulabili  
e componibili, per una completa libertà progettuale in  
contesti living e professionali.

## Family Index

Architectural Lighting



CARTESIO

AUROOM  
BOND  
GLOBE  
MASTER  
QUEEN  
SPOTLIGHT  
SLASH



**Cartesio characterises settings with discretion and conviction. It consists of a slender metal profile, dimmable led lights and a selection of different lamps for use as accessories, in order to create a more or less rich composition.**

Cartesio caratterizza gli ambienti con discrezione e decisione: è formato da un profilo sottile in metallo, luci a led dimmerabili e diverse tipologie di lampade da utilizzare come accessori per rendere più o meno ricca o luminosa la composizione tra cui scegliere.





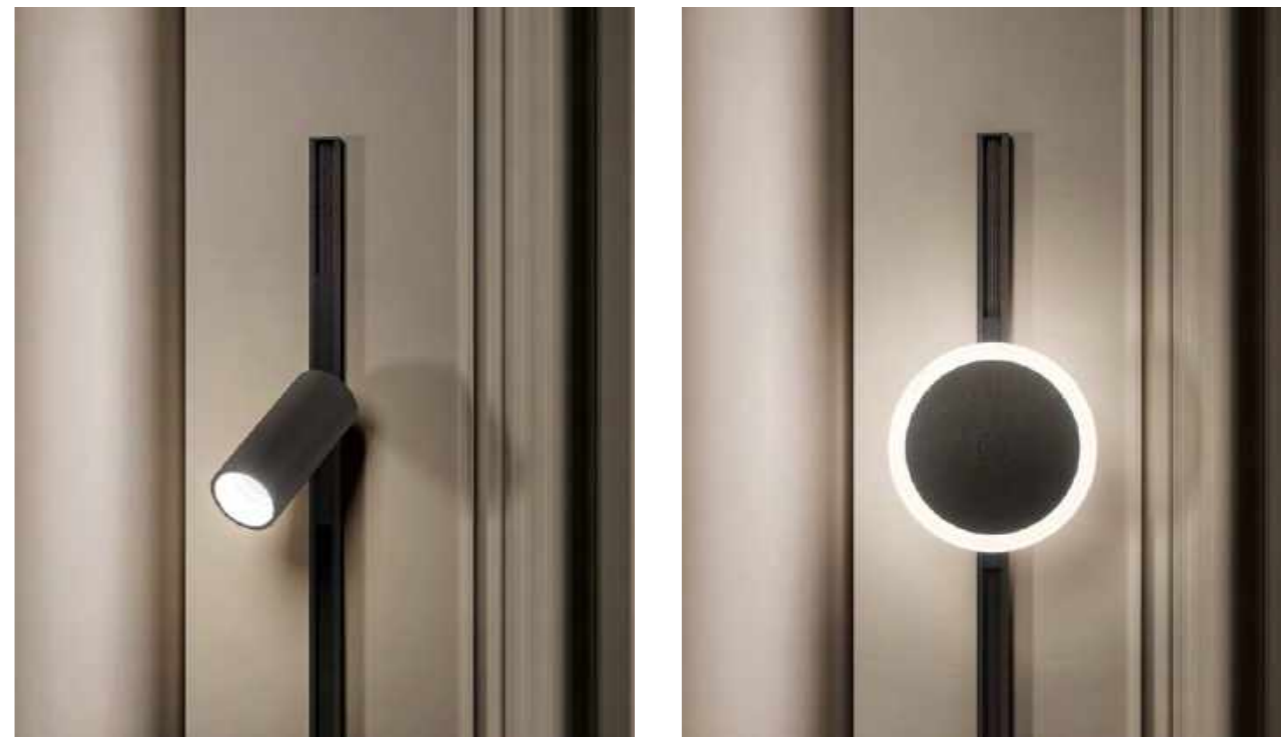

**Designed to respond to a multitude of style requirements, Cartesio can be installed horizontally or vertically, wall or ceiling mounted, thanks to a series of combinable joints.**

Progettato per rispondere a molteplici esigenze di stile, Cartesio si può installare sia in orizzontale, che in verticale, a parete e a soffitto, grazie a una serie di giunzioni combinabili.



**Light points can be positioned along the track of Cartesio, such as spotlights, spheres, bars and other decorative elements, to personalise the lighting of settings big and small.**

È possibile posizionare lungo il binario di Cartesio punti luce quali faretti, sfere, barre e altri elementi decorativi, per personalizzare l'atmosfera luminosa di ambienti di ampie e piccole dimensioni.







**The Cartesio system marks the discovery of a new frontier of lighting: different options are available to direct light, including continuous, concentrated, diffuse or radiating forms, for tailored visual comfort.**

Con il sistema Cartesio nasce una nuova frontiera dell'illuminazione: è possibile scegliere tra diverse opzioni per direzionare la luce, tra cui continua, concentrata, diffusa o radente, per un comfort visivo su misura.

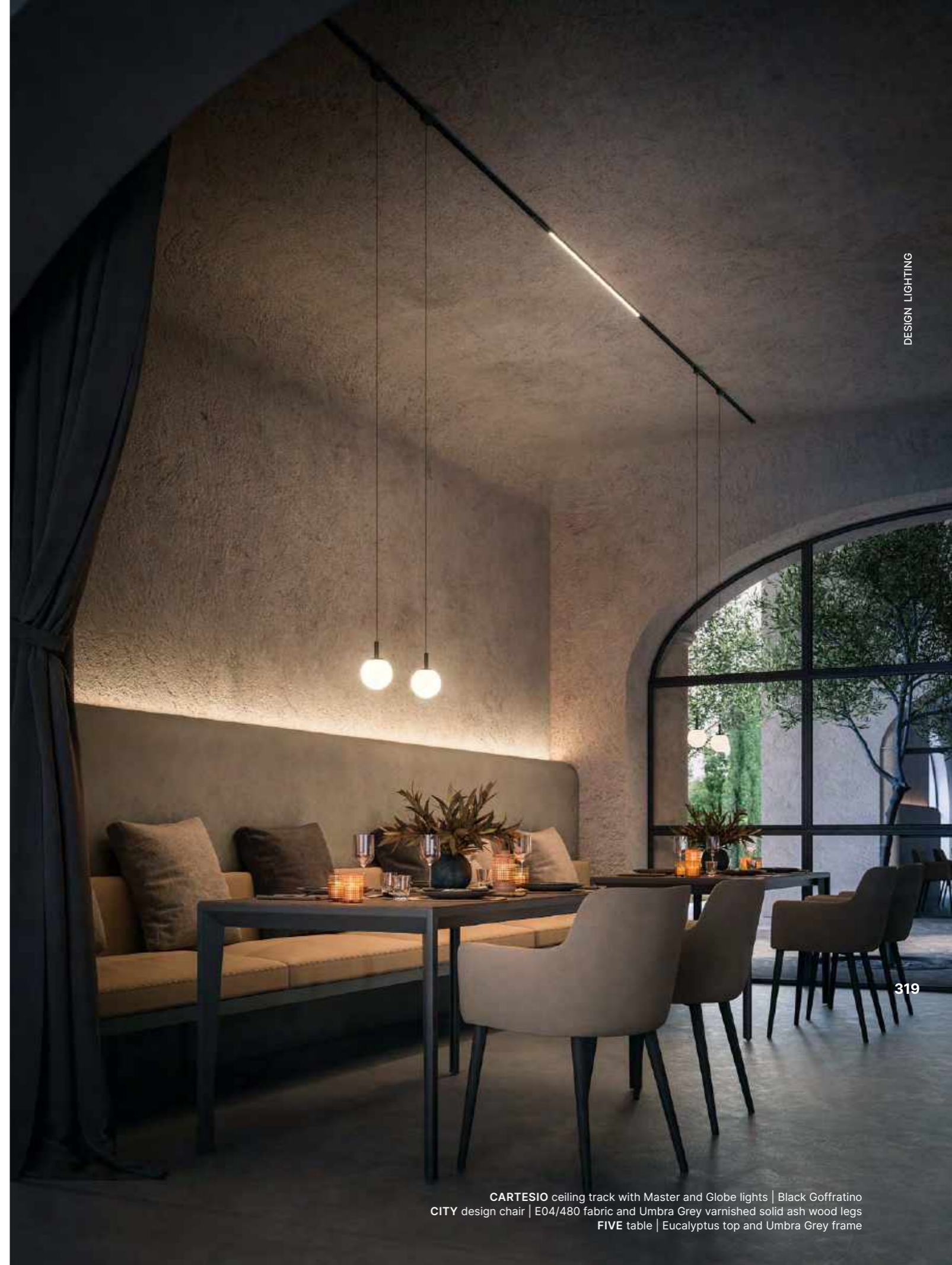





**Designed to provide elegant and functional lighting in a variety of settings, Cartesio guarantees the visual well-being of people, even in business spaces, encouraging concentration and productivity.**

Progettato per illuminare diversi tipi di contesti in modo elegante e funzionale, Cartesio garantisce il benessere visivo delle persone anche negli spazi business, favorendo concentrazione e produttività.

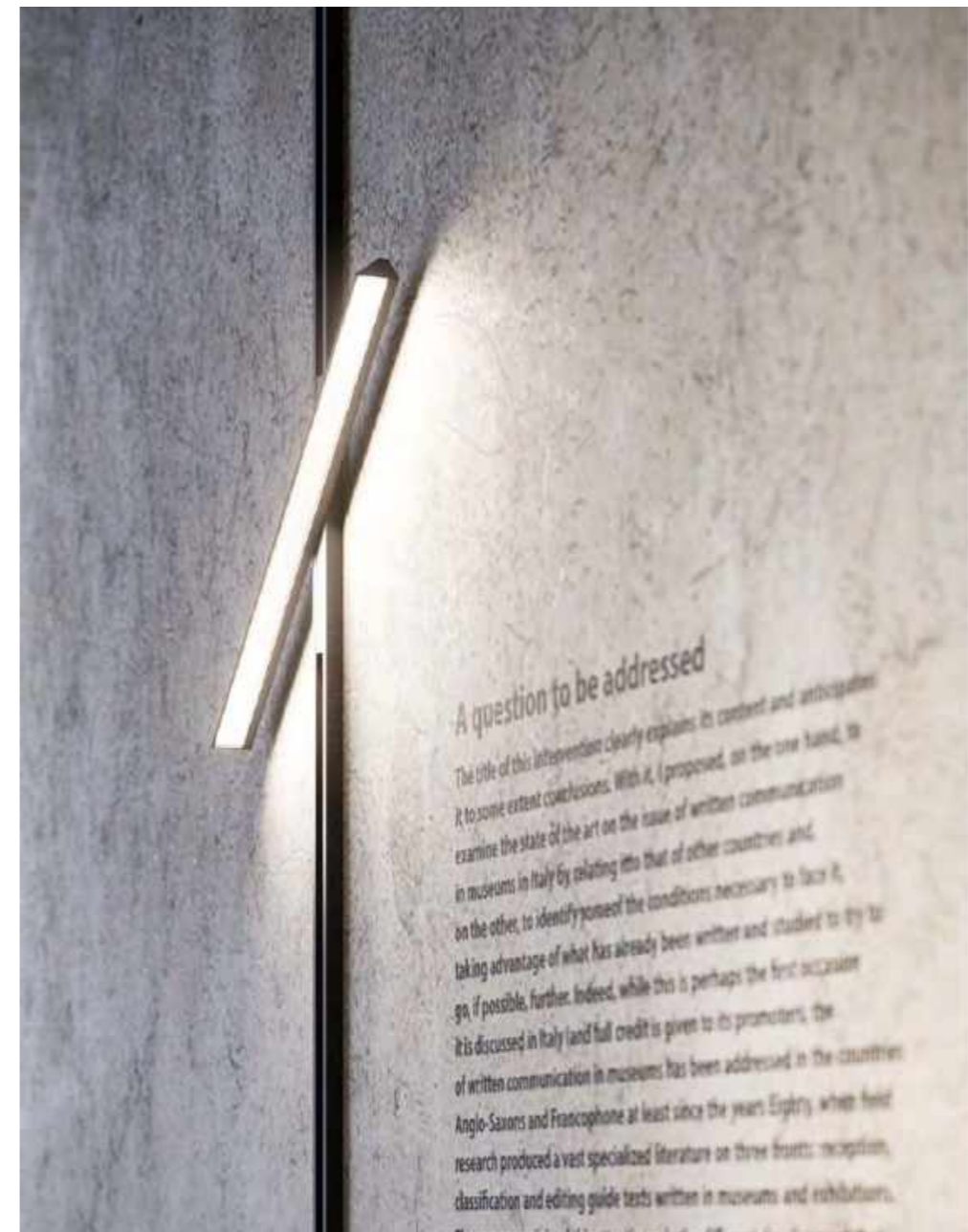





**Simple, linear, functional, with a strong aesthetic impact and adjustable in line with the intended context: Cartesio can be shaped according to design requirements, offering numerous possibilities for interpretation.**

Semplice, lineare, funzionale, dal forte impatto estetico e modulabile in linea con il contesto di destinazione: Cartesio si lascia plasmare a seconda delle esigenze progettuali, offrendo numerose possibilità di installazione.

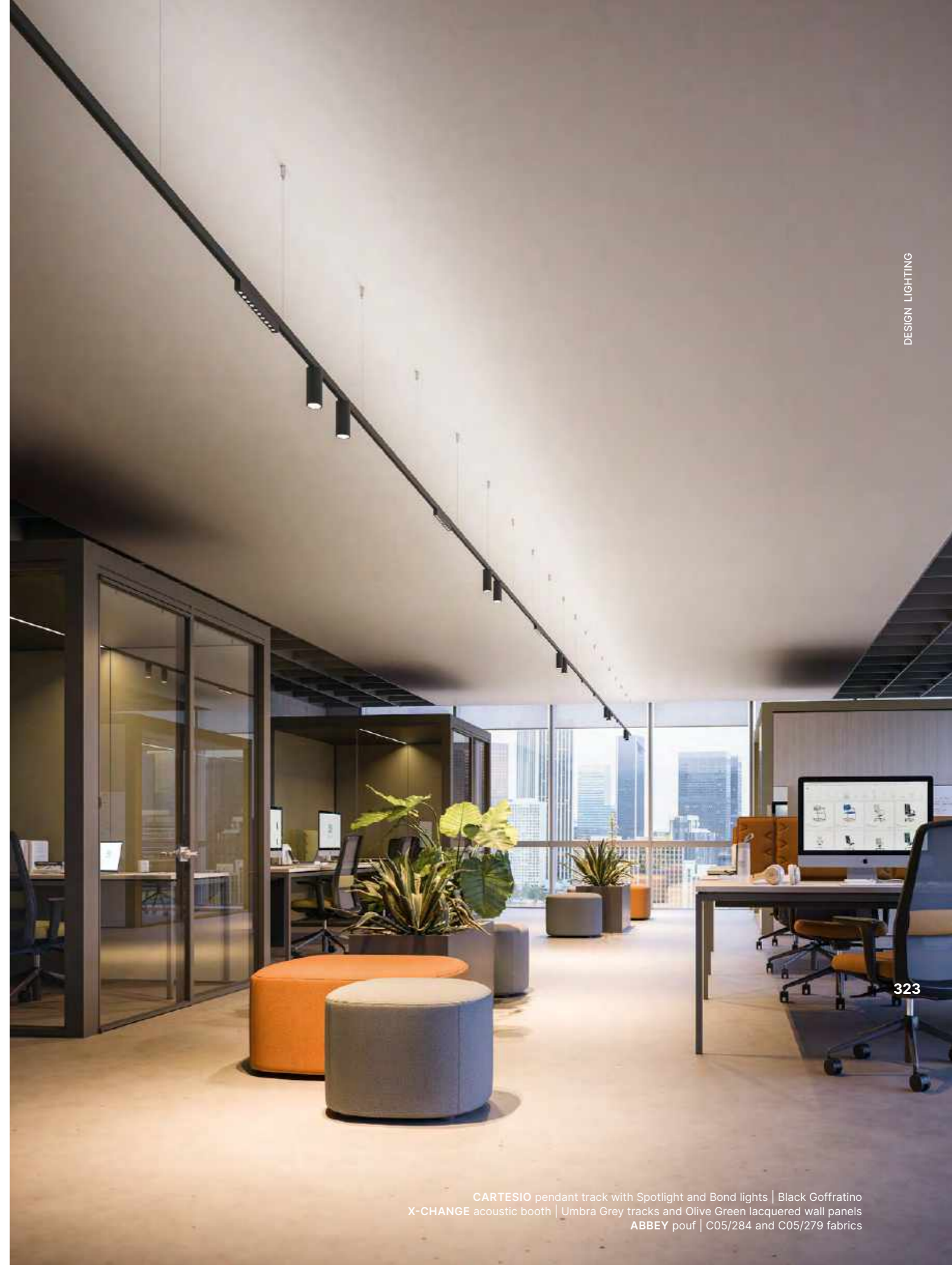



Wall / Ceiling track

CARTESIO

Micro track 48V  
Micro binario 48V

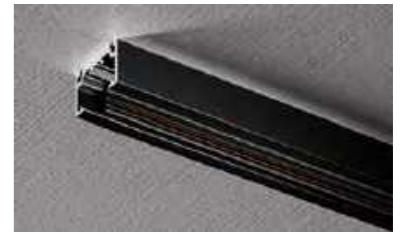
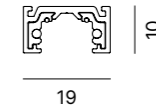

CE IP20

LENGHT / LUNGHEZZA  
1000 - 2000 - 3000 mm

FINISH / FINITURA  
Black Goffratino



Cartesio wall/ceiling tracklights

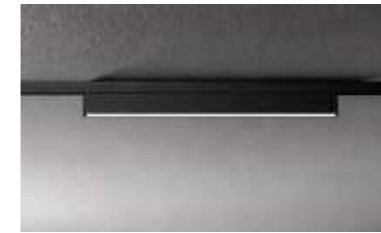

1. AUROOM



2. MASTER



3. BOND



4. ADJUSTABLE SPOTLIGHT



5. SLASH



6. GLOBE



7. GLOBE PENDANT

Specifications at pages 328-329



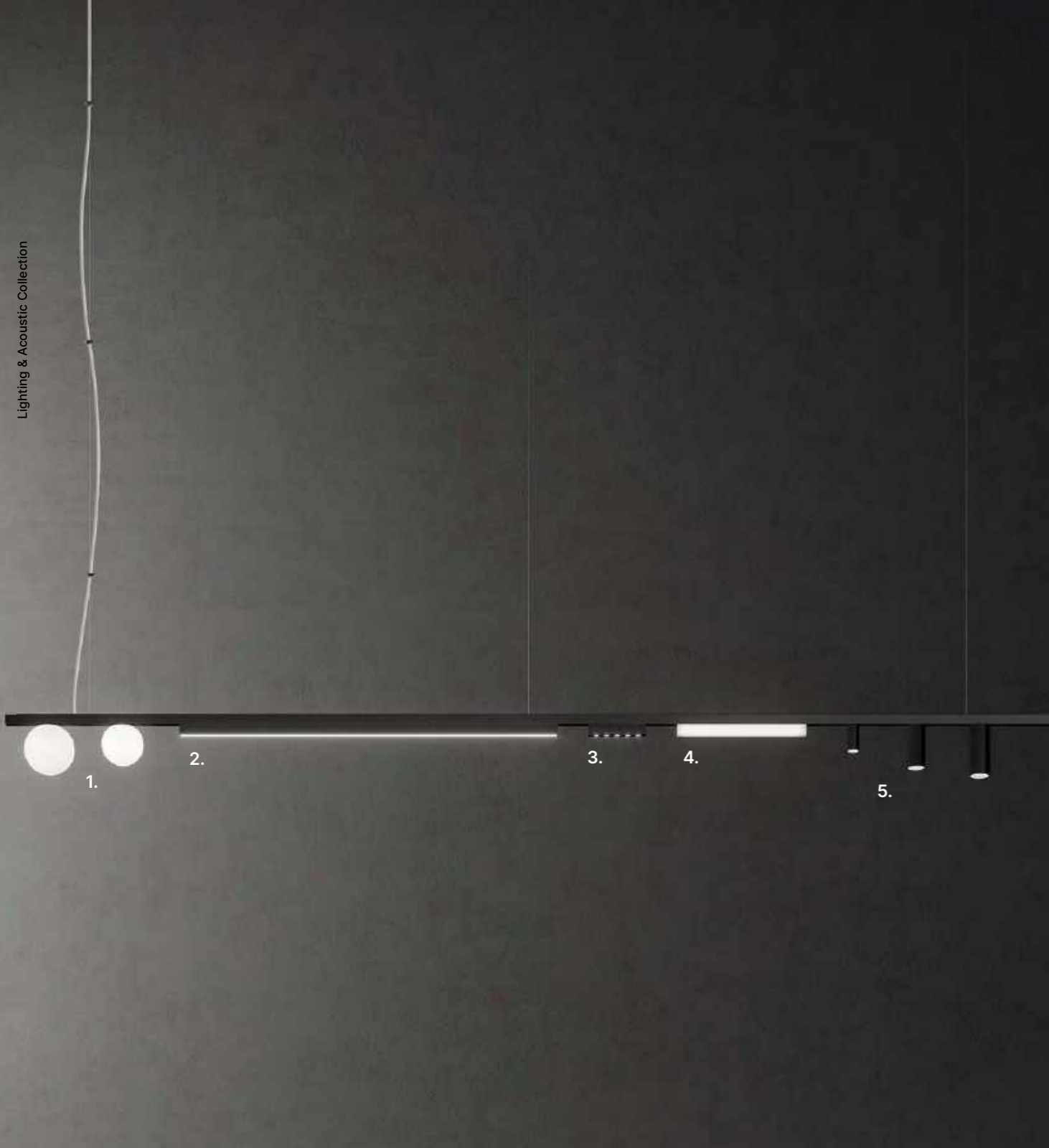

Pendant track

CARTESIO

Micro track 48V  
Micro binario 48V

CE IP20

LENGHT / LUNGHEZZA  
1000 - 2000 - 3000 mm

FINISH / FINITURA  
Black Goffratino

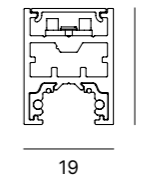

Cartesio pendant tracklights



1. GLOBE

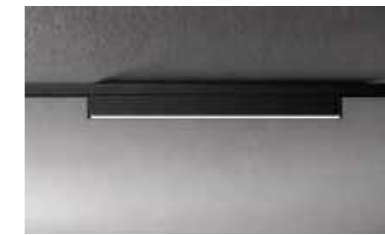

2. AUROOM



3. BOND



4. MASTER



5. FIXED SPOTLIGHT

**Auroom**

Straight down light W. 315/915mm  
Lampada lineare diretta L. 315/915 mm

CRI90  
600 lm / 1800 lm  
2700K / 3000K

CE IP20 LED 48V MacAdam Step 3



**Master**

Straight diffused light W. 315/915mm  
Lampada lineare diffusa L. 315/915 mm

CRI90  
600 lm / 1800 lm  
2700K / 3000K

CE IP20 LED 48V MacAdam Step 3



**Slash**

Triangular lamp W. 314mm  
Lampada triangolare L. 314mm

CRI90  
600 lm  
2700K / 3000K

CE IP20 LED 48V MacAdam Step 3



**Bond**

5 or 10-lights spotlight  
Faretto 5 o 10 luci

CRI90  
525 lm / 1050 lm  
2700K / 3000K

CE IP20 LED 48V 25-60°



**Spotlight**

Adjustable spotlights Ø 30/43/53 mm  
Faretti orientabili Ø 30/43/53 mm

3,2W / 10,6W / 13,9W - CRI90  
177 lm / 720 lm / 1065 lm  
2700K / 3000K

CE IP20 LED 48V 15-30° 15-30° MacAdam Step 3



**Spotlight**

Fixed spotlights Ø 30/43/53 mm  
Faretti fissi Ø 30/43/53 mm

3,2W / 10,6W / 13,9W - CRI90  
177 lm / 720 lm / 1065 lm  
2700K / 3000K

CE IP20 LED 48V 15-30° MacAdam Step 3



**Globe**

Round lamp Ø 100/120 mm  
Lampada sfera Ø 100/120 mm

CRI90  
420 lm  
2700K / 3000K

CE IP20 LED 48V



**Globe**

Round pendant lamp Ø 100/120 mm  
Lampada sfera a sospensione Ø 100/120 mm

CRI90  
420 lm  
2700K / 3000K

CE IP20 LED 48V





## Office Lighting

**Light projects.**  
 Responding to the operative and executive needs of an office means being able to skilfully combine the brightness, tonality and position of lights. Office lamps take centre stage as fundamental elements of visual comfort for people.

Progetti luminosi.  
 Rispondere alle esigenze operative e di rappresentanza di un ufficio significa combinare con sapienza intensità, tonalità e collocazione della luce. Le lampade da ufficio diventano protagoniste insostituibili del comfort visivo delle persone.



## Family Index

Office Lighting

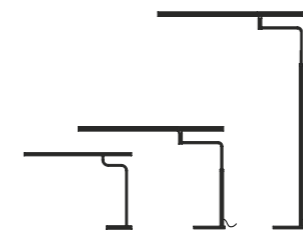

MINISTICK

MICROSTICK TABLE - 332  
 MINISTICK TABLE - 338  
 MINISTICK FLOOR - 344



MORE

MORE FLOOR - 350

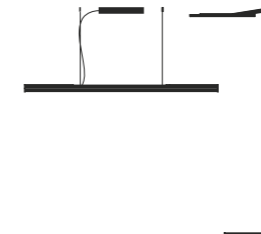

FLY

FLY FLOOR - 356  
 FLY PENDANT - 362



EUSTRESS

EUSTRESS PENDANT - 368



LIGHTSOUND

TRIANGLE PENDANT LAMP  
 EASY PENDANT LAMP  
 CLOAK ACOUSTIC PANEL  
 PETAL ACOUSTIC PANEL  
 374 - 397

# MICROSTICK

designed by Moreno De Giorgio

**Compact functionality.  
Efficient and minimal,  
Microstick is the desk  
lamp par excellence, at  
home or in the office. The  
soft led light is adjustable  
with a touch sensor for  
superlative comfort.**

Funzionalità compatta.

Efficiente e minimale, Microstick è la lampada da scrivania per eccellenza, a casa o in ufficio. La luce soft a led è regolabile con un sensore touch per il massimo comfort.



TABLE LAMPS







### Table lamp

## MICROSTICK

Table lamp in powder coated aluminium.  
Lampada da tavolo in alluminio verniciato.

10W LED  
220-240V  
3000K  
CRI80  
Touch Dimm

CE IP20  800lm

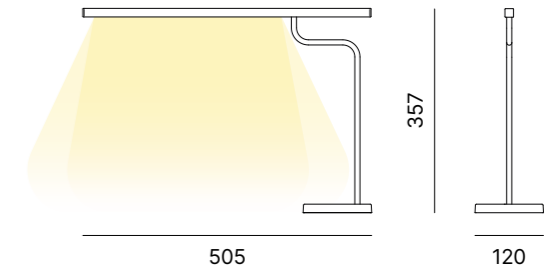

#### LAMP FINISH OPTIONS FINITURE LAMPADA



Matt White



Black  
Goffratino

#### DETAILS DETTAGLI



Touch dimmer  
function

### Ministick collection



MINISTICK TABLE  
338

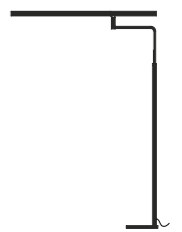

MINISTICK FLOOR  
344

# MINISTICK

designed by Moreno De Giorgio

**Directions of light.  
The essential design of  
Ministick makes it perfect  
for versatile use, thanks  
to the microprismatic high  
efficiency diffuser and the  
position adjustment of this  
table lamp.**

Direzioni di luce.

Il design essenziale di Ministick si presta a un utilizzo versatile, grazie al diffusore microprismatico ad alta efficienza e alla possibilità di regolare la posizione di questa lampada da tavolo



TABLE LAMPS





Table lamp

MINISTICK

Table lamp in powder coated aluminium. Brushed anodized aluminium shade and high-efficiency microprismatic diffuser.

Lampada da tavolo in alluminio verniciato. Paralume in alluminio spazzolato anodizzato e diffusore microprismatico ad alta efficienza.

15W LED  
110-240V  
3000K  
CRI90  
Touch Dimm

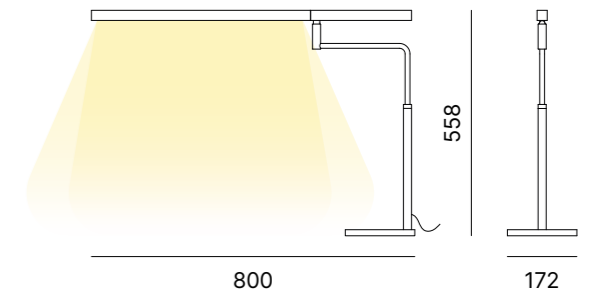

CE IP20 24V 1850lm MacAdam Step 3

LAMP FINISH OPTIONS  
FINITURE LAMPADA



Matt White

Black Goffratino

DETAILS  
DETTAGLI

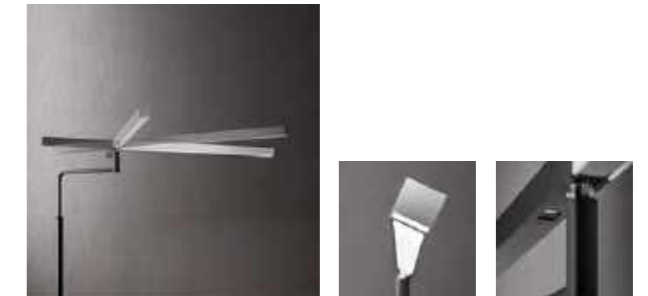

±170° rotation

±45° rotation

Touch dimmer function

Ministick collection

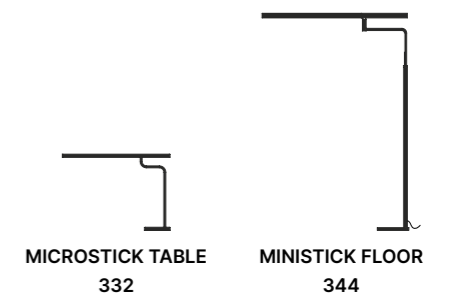

# MINISTICK

designed by Moreno De Giorgio

**Slender brightness.  
Technology and beauty  
meet in the Ministick floor  
lamp: the simple and elegant  
lines enclose a strong and  
determined character and  
are suitable for a world of  
different configurations.**

Slanciata luminosità.

Tecnologia e bellezza si incontrano nella lampada da terra  
Ministick: le linee semplici ed eleganti racchiudono un carattere  
forte e deciso e si prestano a un mondo di configurazioni diverse.



FLOOR LAMPS







348

## Floor lamp

## MINISTICK

Floor lamp in powder coated aluminium. Brushed anodized aluminium shade and high-efficiency microprismatic diffuser.

Lampada da terra in alluminio verniciato. Paralume in alluminio spazzolato anodizzato e diffusore microprismatico ad alta efficienza.

15W LED  
110-240V  
3000K  
CRI90  
Touch Dimm

CE IP20   24V 1850lm  MacAdam Step 3

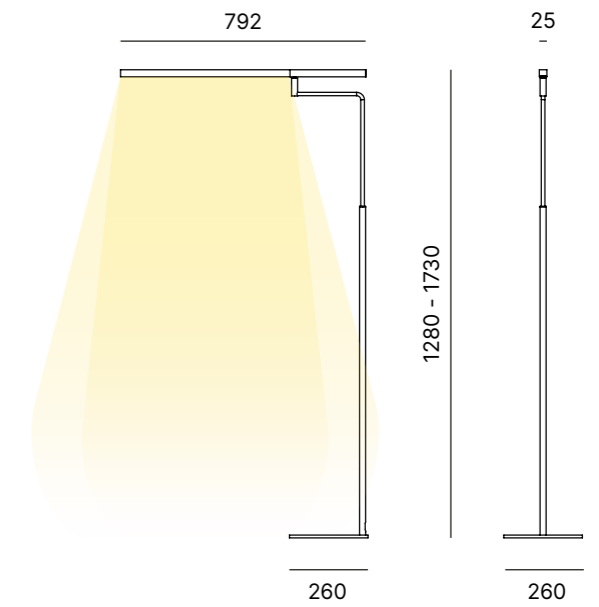

DESIGN LIGHTING

LAMP FINISH OPTIONS  
FINITURE LAMPADA

Matt White

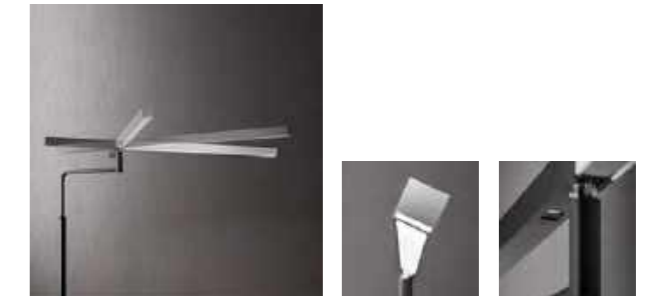
Black  
GoffratinoDETAILS  
DETTAGLI

±170° rotation

±45° rotation

Touch dimmer  
function

## Ministick collection

349

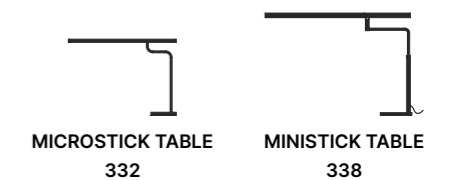
MICROSTICK TABLE  
332MINISTICK TABLE  
338



designed by Moreno De Giorgio

**Measured forms.  
Logic, power and linearity:  
in More proportions,  
technology and attention  
to details bring to life  
an essential and high-  
performance lamp,  
ideal for offices with a  
contemporary look.**

Forme misurate.

Logica, potenza e linearità: in More le proporzioni, la tecnologia e la cura dei dettagli danno vita a una lampada essenziale e performante, ideale per gli uffici dal look contemporaneo.



FLOOR LAMPS







354

## Floor lamp

MORE

Floor lamp in powder coated aluminium.  
Lampada da terra in alluminio verniciato.

More 8	More 12	More 16
64W LED	94W LED	124W LED
8000 lm	12000 lm	16000 lm
110-240V	110-240V	110-240V
3000K	3000K	3000K
CRI90	CRI90	CRI90
Touch Dimm	Touch Dimm	Touch Dimm

CE IP20   24V  MacAdam Step 3

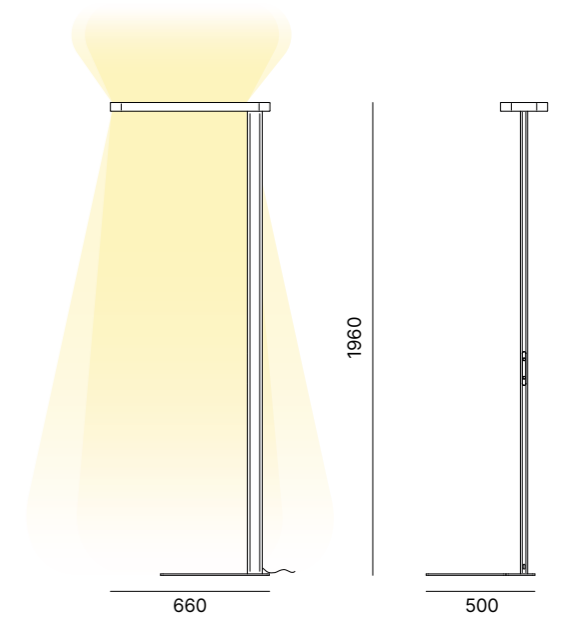
LAMP FINISH OPTIONS  
FINITURE LAMPADA

Matt White

Black  
goffratinoDETAILS  
DETTAGLITouch dimmer  
function

355



**Sophisticated lightness.  
Fly stands out for its  
aerodynamic silhouette and  
fluid design: a floor lamp  
that ensures a characteristic  
and enveloping light, ideal  
for workspaces with a  
refined soul.**

**Sofisticata leggerezza.  
Fly si distingue per la silhouette aerodinamica e il design fluido:  
una lampada da terra che assicura una luce caratteristica e  
avvolgente, ideale per gli spazi di lavoro dall'animo ricercato.**







FLY floor lamp | Matt White

Floor lamp

FLY

Floor lamp in powder coated aluminium.  
Lampada da terra in alluminio verniciato.

Fly 8	Fly 12	Fly 16
70W LED	91W LED	130W LED
8400 lm	11400 lm	16400 lm
110-240V	110-240V	110-240V
3000K	3000K	3000K
CRI90	CRI90	CRI90
Touch Dimm	Touch Dimm	Touch Dimm

CE IP20 LED 24V MacAdam Step 3

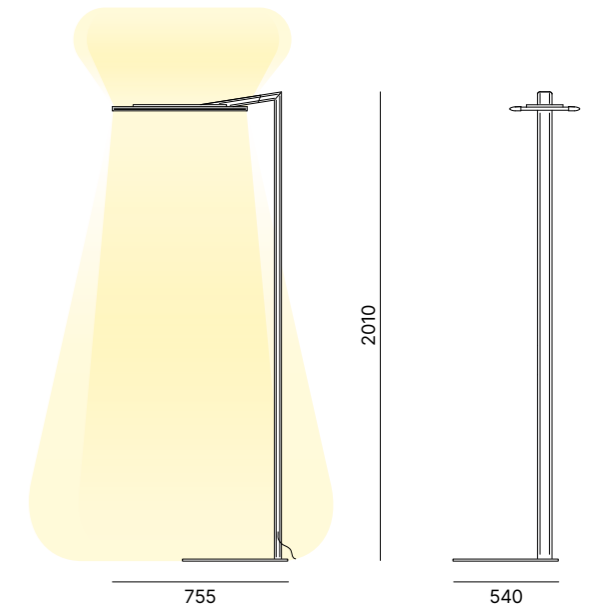

LAMP FINISH OPTIONS  
FINITURE LAMPADA



Matt White

Black goffratino

DETAILS  
DETTAGLI



Touch dimmer function

Fly collection

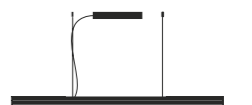

FLY PENDANT  
362



**Aerial delicacy.  
Pure lines with an iconic  
style: the Fly suspension  
lamp illuminates design  
environments with a touch  
of shining beauty, thanks to  
the white and thin structure  
that characterises it.**

**Delicatezza aerea.  
Linee pure dallo stile iconico: la lampada a sospensione  
Fly illumina gli ambienti di design con un tocco di  
splendente bellezza, grazie alla struttura bianca e  
sottile che la caratterizza.**



PENDANT LAMPS





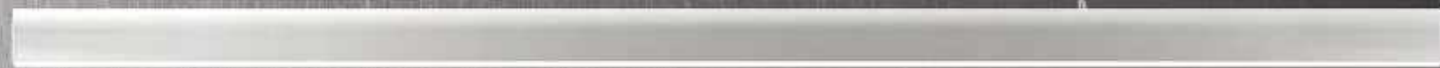

Pendant lamp

FLY

Pendant lamp in powder coated aluminium.  
Lampada a sospensione in alluminio verniciato.

Fly 120	Fly 160
28W LED	38W LED
2400 lm	3200 lm
3000K	3000K
CRI90	CRI90
ON-OFF	ON-OFF

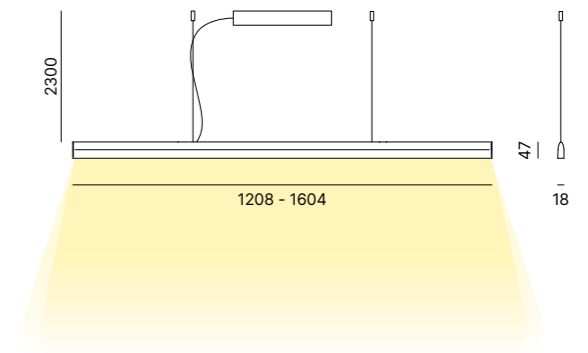

CE IP20 LED 24V MacAdam Step 3

LAMP FINISH OPTIONS  
FINITURE LAMPADA



Matt White Black Goffratino Gold Bronze Corten

Fly collection



FLY FLOOR  
356

# EUSTRESS

designed by Moreno De Giorgio

**Bright paths.**  
Eustress has a minimal and unconventional spirit, defined by its trapezoidal shape: with the latest generation LED and microprismatic diffuser, this lamp creates a contemporary form of lighting.

*Vie luminose.*

Eustress ha uno spirito minimale e anticonformista, definito dalla sua forma trapezoidale: con il led di ultima generazione e il diffusore microprismatico, questa lampada crea una forma contemporanea di illuminazione.



PENDANT LAMPS





Pendant lamp

Pendant lamp in powder coated aluminium.  
Lampada a sospensione in alluminio verniciato.

Eustress 120	Eustress 160
56W LED	76W LED
4800 lm	6400 lm
3000K	3000K
CRI90	CRI90
ON-OFF   All in one	ON-OFF   All in one

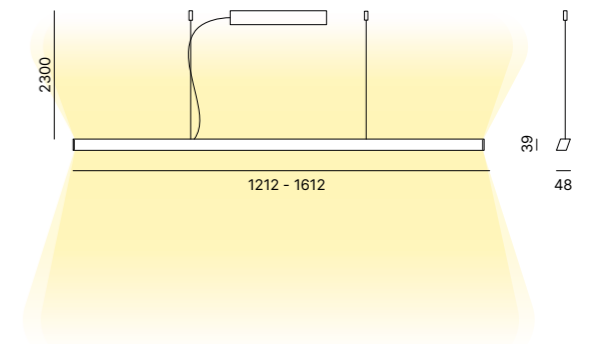

CE IP20 LED 24V MacAdam Step 3

LAMP FINISH OPTIONS  
FINITURE LAMPADA



# LIGHTSOUND

designed by Moreno De Giorgio

**Sensory design.  
Visual and auditory  
well-being: this is what  
is perceived in a public  
space furnished with  
Lightsound, the modular  
system of lights and  
sound-absorbing panels.**

Design sensoriale.  
Benessere visivo e uditivo: è ciò che si percepisce in  
uno spazio pubblico arredato con Lightsound, il sistema  
componibile di luci e pannelli fonoassorbenti.



ACOUSTIC ELEMENTS









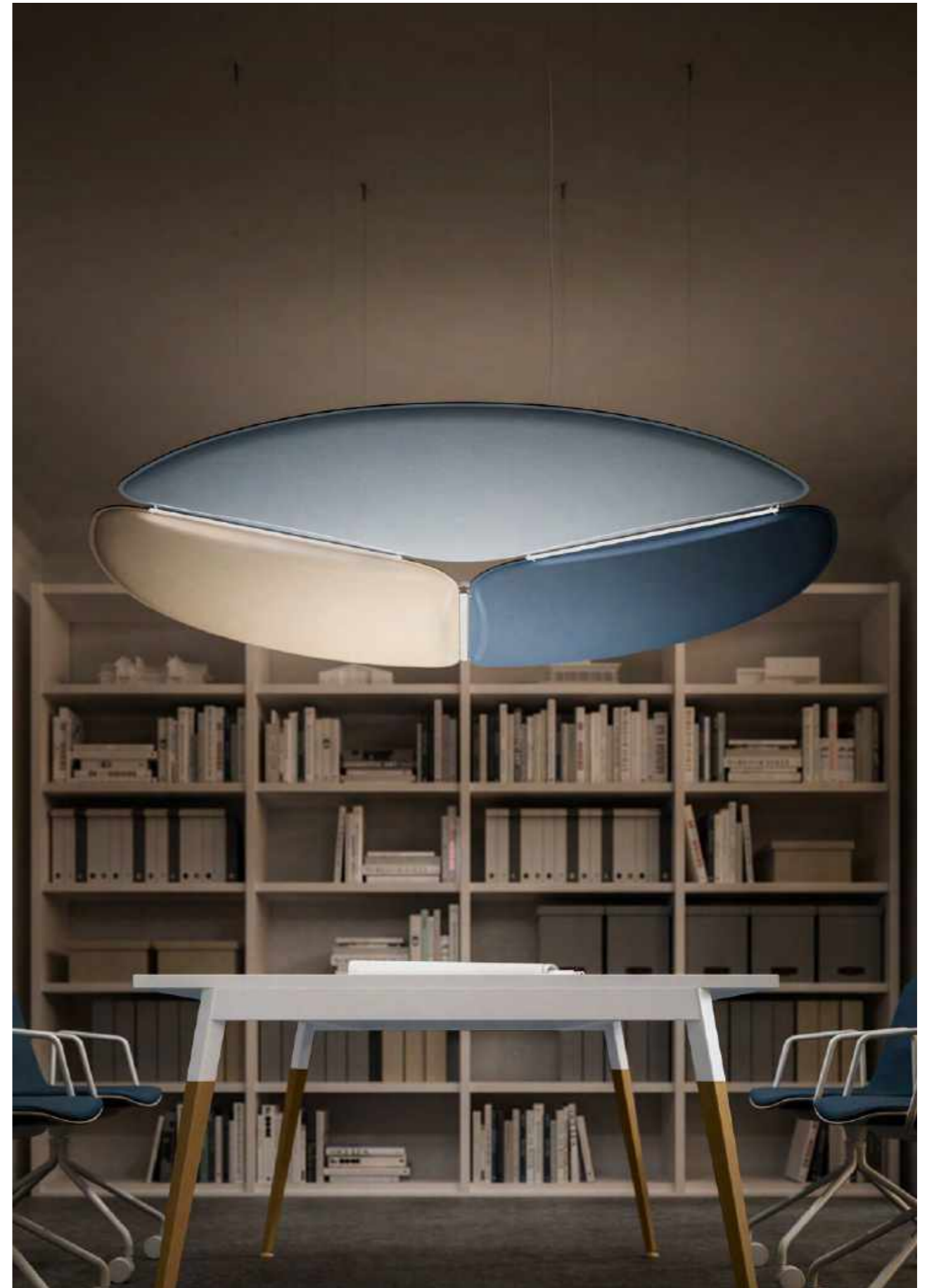
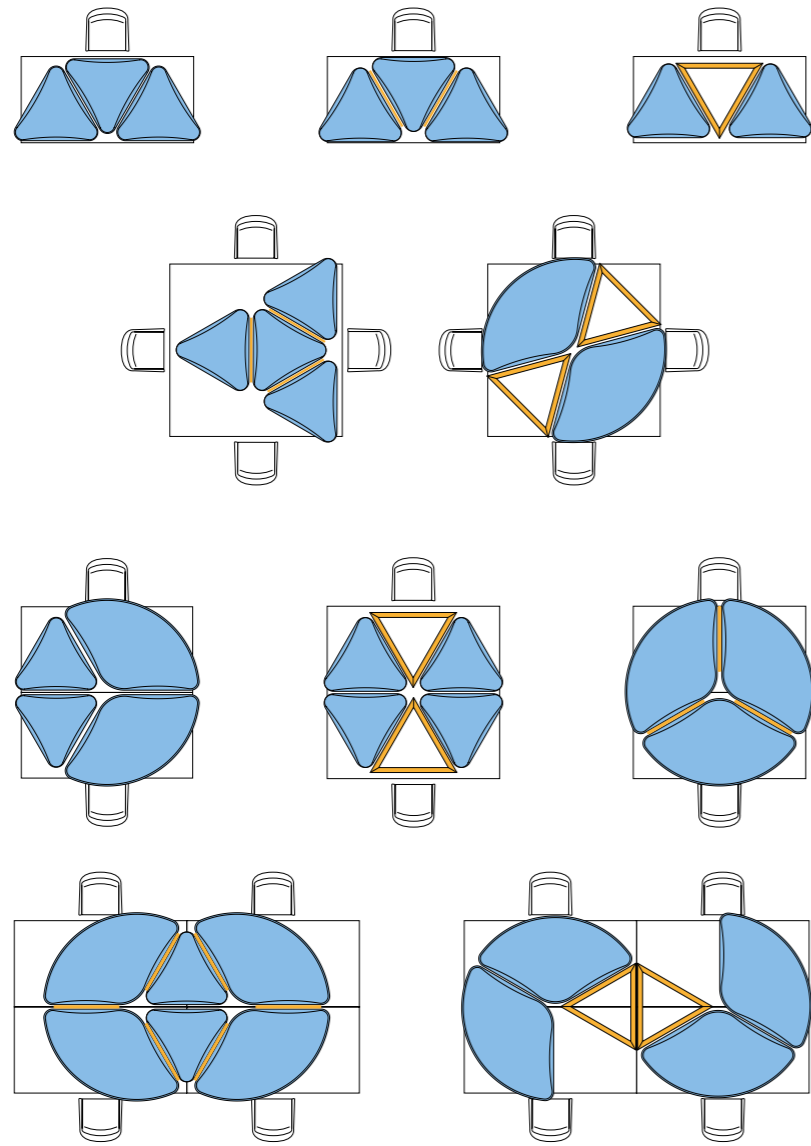





382

**Panels are triangular or with a 120° angle and can be matched with Easy and Triangle leds. Lightsound can be installed suspended or wall hung to create shared spaces that are a pleasure to inhabit.**

I pannelli sono triangolari oppure con un angolo di 120° e si possono abbinare ai led Easy e Triangle. Lightsound si installa sia a sospensione sia a parete per creare spazi condivisi piacevoli da vivere.



383





386

**Lightsound can be assembled according to taste and customised with different cover colour options. The panels can also be arranged in the ceiling mounted cascade version, which is ideal for open spaces, hotel lobbies and restaurants.**

Lightsound è componibile a piacimento e personalizzabile nei colori dei rivestimenti. I pannelli si possono disporre anche nella versione a cascata dal soffitto, ideali per open space, sale di hotel e ristoranti.



387





Pendant lamp

TRIANGLE

Pendant lamp in anodized or powder coated aluminium.  
Lampada a sospensione in alluminio anodizzato o verniciato.

Down light	Up/Down light
51W LED	90W LED
4200 lm	7500 lm
3000K	3000K
CRI90	CRI90
ON-OFF   All in one	ON-OFF   All in one

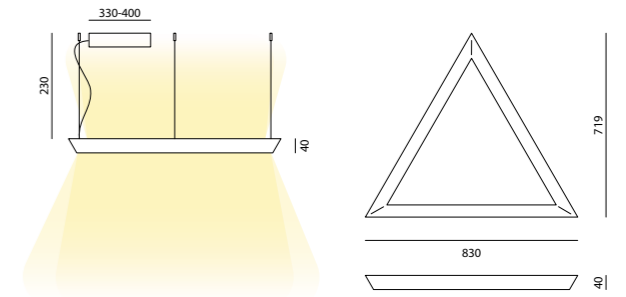

CE IP20   24V  MacAdam Step 3

LAMP FINISH OPTIONS  
FINITURE LAMPADA



Anodized aluminium

Matt White



### Pendant lamp

EASY

Pendant lamp in anodized aluminium.  
Lampada a sospensione in alluminio anodizzato.

15W LED  
3000K  
CRI80

CE IP20 LED 24V 1200lm MacAdam Step 3

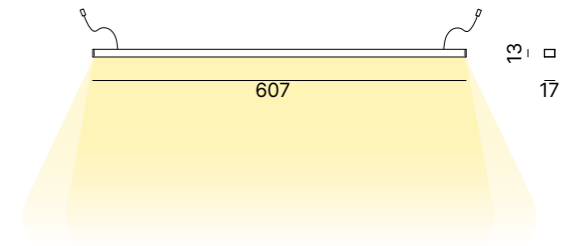

#### LAMP FINISH OPTIONS FINITURE LAMPADA



Anodized aluminium





Acoustic panel

CLOAK

Pendant or wall-mounted sound-absorbing triangular panel, fabric upholstered.  
Pannello fonoassorbente triangolare, a parete o sospensione, rivestito in tessuto.

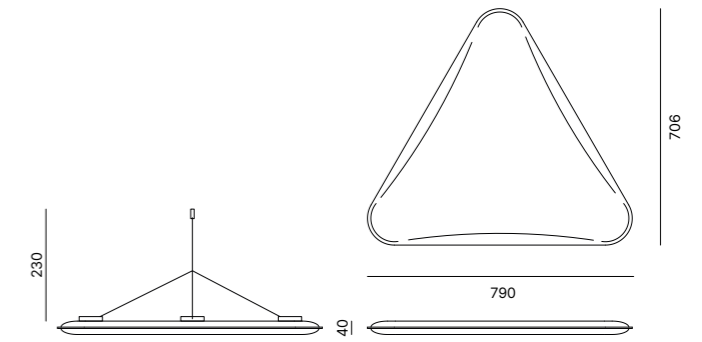

PANELS FINISH OPTOINS  
FINITURE PANNELLI

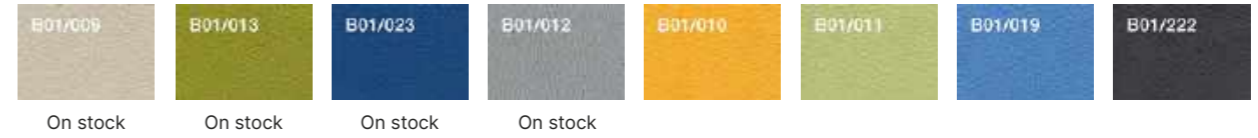

DETAILS  
DETTAGLI



Linking



### Acoustic panel

### PETAL

Pendant or wall-mounted sound-absorbing 120° panel, fabric upholstered.  
Pannello fonoassorbente 120°, a parete o sospensione, rivestito in tessuto.

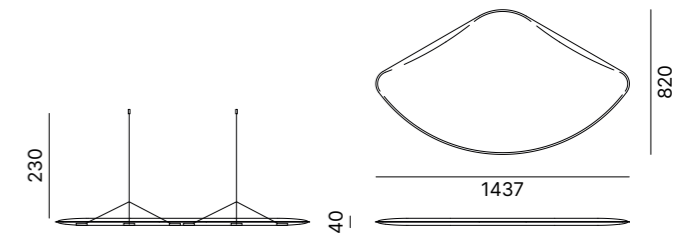

#### PANELS FINISH OPTOINS FINITURE PANNELLI



#### DETAILS DETTAGLI



Linking



# PENDANT CLOAK

Pendant sound-absorbing triangular panel, fabric upholstered.  
Pannelli triangolari fonoassorbenti rivestiti in tessuto, a sospensione verticale.

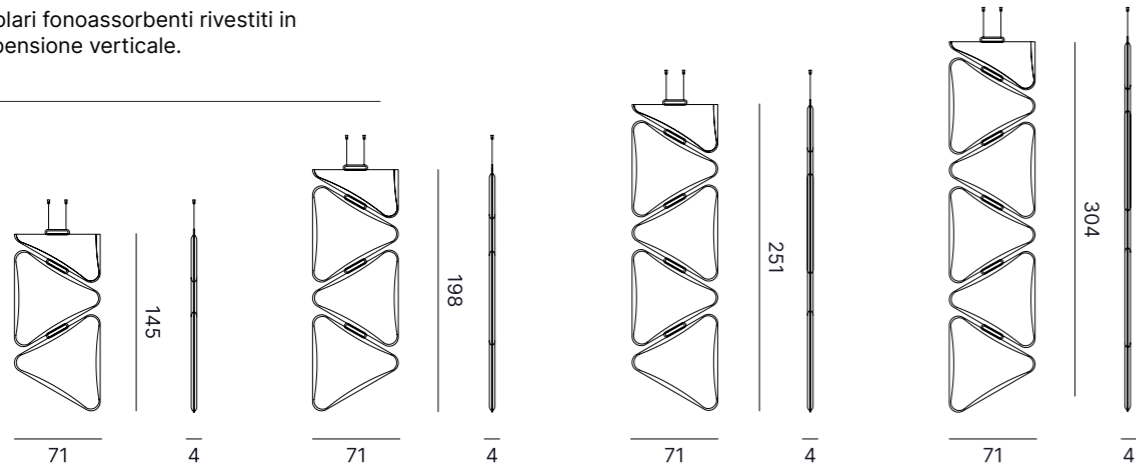

PANELS FINISH OPTOINS  
FINITURE PANNELLI

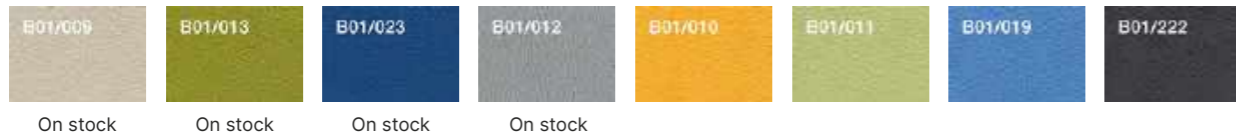

# PETAL FLOOR STAND

Powder coated metal frame. 3 fabric upholstered sound-absorbing panels.  
Piantana in metallo verniciato. 3 pannelli fonoassorbenti 120° rivestiti in tessuto.

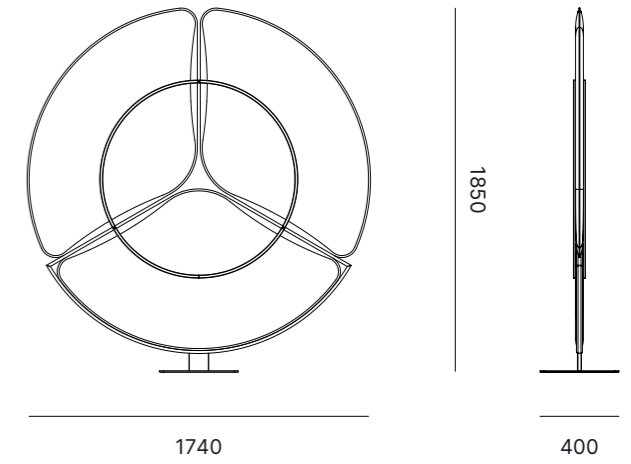

PANELS FINISH OPTOINS  
FINITURE PANNELLI



FRAME FINISH OPTIONS  
FINITURE PIANTANA

